



SAILOR
SYSTEM 4000
MF/HF 150W

Technical Manual

Please Note:

Any responsibility or liability for loss or damage in connection with the use of this product and the accompanying documentation is disclaimed. The information in this quick guide is furnished for informational use only, is subject to change without notice, may contain errors or inaccuracies, and represents no commitment whatsoever. This agreement is governed by the laws of Denmark.

Doc. No.: M4500BGB0

Issue: C/0537

CONTENTS

		PAGE
1	INTRODUCTION	1-1
1.1	GENERAL DESCRIPTION	1-1
1.2	TECHNICAL DATA	1-1
2	INSTALLATION	2-1
2.1	DESCRIPTION	2-1
2.2	MOUNTING THE UNITS	2-1
2.3	GROUND CONNECTIONS	2-5
2.4	GROUNDING CONSIDERATIONS	2-5
2.5	ANTENNAS	2-7
2.6	POWER SUPPLY	2-10
2.7	INTERCONNECTION OF UNITS	2-10
2.8	CONNECTOR MOUNTING INSTRUCTIONS	2-15
2.9	POSITION AND TIME INFORMATION	2-16
2.10	OPTIONS MENU - SETTING UP THE SYSTEM	2-16
2.11	DSC PROGRAMMING	2-17
2.12	BATTERY ALARM ADJUSTMENT	2-18
2.13	FACTORY RESETTING	2-18
2.14	FINAL INSTALLATION CHECK	2-18
3	TECHNICAL DESCRIPTION	3-1
3.1	CONTROL UNIT	3-1
3.2	TRANSCEIVER UNIT	3-1
3.3	CONTROL / INTERCON MODULE 636510	3-1
3.4	SYNTH. AND DSC WR MODULE 636511	3-1
3.5	RX/EX SIGNAL PATH MODULE 636515	3-2
3.6	PA AND FILTERS MODULE 636520	3-2
3.7	SMPS MODULE 636530	3-2
3.8	TRANSCEIVER UNIT BLOCK DIAGRAM	3-3
3.9	TRANSCEIVER UNIT INTERCONNECTION DIAGRAM	3-4
3.10	ANTENNA TUNING UNIT	3-5
3.11	ANTENNA TUNING UNIT BLOCK DIAGRAM	3-5
3.12	POWER CONTROL AND PROTECTION SYSTEM	3-6
3.13	POWER CONTROL AND PROTECTION SYSTEM	3-7
4	SERVICE	4-1
4.1	PREVENTIVE MAINTENANCE	4-1
4.2	REALIGNMENT OF MASTER OSCILLATOR	4-1
4.3	SOFTWARE UPDATE	4-2
4.4	TROUBLE SHOOTING	4-2
4.5	POWER PROTECTION	4-3
4.6	SELF TEST	4-5
5	SPARE PART EXCHANGE	5-1
5.1	DISASSEMBLING THE TRANSCEIVER UNIT	5-1
5.2	TRANSCEIVER UNIT MODULE LOCATION	5-1
5.3	SPARE PARTS LIST	5-4
5.4	REQUIRED SERVICE TOOL	5-4
5.5	ACCESSORY LIST	5-4

CONTENTS

1	INTRODUCTION	1-1
1.1	GENERAL DESCRIPTION	1-1
1.2	TECHNICAL DATA	1-1

1 INTRODUCTION

1.1 GENERAL DESCRIPTION

The 150 W MF/HF transceiver with integrated DSC is designed for maritime applications in voluntary as well as compulsorily fitted vessels. It offers simplex and semi-duplex SSB radiotelephone communication in the maritime mobile frequency bands between 1.6 and 30 MHz. With the built-in DSC modem and the 2187.5 kHz DSC watch receiver the equipment forms an ideal system for MF GMDSS installations.

The equipment consists of a compact transceiver control unit, a fully remote controlled transceiver unit and an automatic antenna tuning unit.

The microprocessor controlled Antenna Tuning Unit automatically matches the impedance of antennas between 8 and 18 metres in length and requires no presetting at the installation. The typical tuning time is 1 s. It is designed for outdoor installation and may be located up to 100 metres from the Transceiver Unit.

The Transceiver Unit contains all receiver and transmitter circuitry. The fully protected solid state 150 W power amplifier cooled by natural convection matches a 50 ohms antenna system, but is normally used in connection with the Antenna Tuning Unit. The DSC modem contains two demodulators, one connected to the built-in watch receiver for continuous watch on the DSC distress frequency 2187.5 kHz, the other connected to the communication receiver which may be used to keep simultaneous watch on other DSC frequencies.

The Control Unit is for operation of radiotelephone as well as DSC functions. Use of the equipment is simple, logic and straight forward. DSC operation is based on the use of soft keys. Guiding texts are provided and the large display is able to show the contents of a complete call in one screen.

The equipment is designed for operation from a 24 V battery. With the optional AC Power Supply unit installed the equipment may be supplied from 115/230 V AC main or emergency supplies with automatic switch-over to 24 V DC supply in the absence of AC supply voltage. Also optionally battery charger for AC is available in the product serie.

The built-in test facilities and easy-to-replace module design of the equipment simplifies the service concept.

1.2 TECHNICAL DATA

150 W MF/HF SSB Radiotelephone with integrated DSC facility and 2187.5 kHz DSC Watch Receiver.

GENERAL

Complies with the relevant IMO performance standards, the ITU Radio Regulations, the ITU-R recommendations and meets the relevant performance specifications of ETSI and IEC.

Operating modes:	Simplex and semi-duplex SSB telephony (J3E) and DSC (J2B), AM broadcast reception (A3E).
Frequency selection:	Direct by keyboard or programmed channels.
Displayed frequency:	Operating modes SSB telephony (J3E) and AM reception (A3E): Carrier frequency. Operating mode DSC (J2B): Up-converted sub-carrier frequency.
Frequency stability:	0.35 ppm. Ageing: Less than 1 ppm/year. Warm-up time: Less than one minute.
Pre-programmed channels:	289 ITU HF telephony channels, 54 ITU MF telephony channels in Region I, 40 ITU DSC frequency pairs.
User programmable channels:	199 frequency pairs with mode (1-199).
User programmable stations:	40 stations with name, MMSI and station channels.

User programmable station channels:	400 frequency pairs with mode, channel number and type.
Scanning:	DSC Watch: up to 6 DSC frequencies, Telephony Watch: up to 10 telephony channels, Multi Watch: one DSC frequency + up to 10 telephony channels. Dual Watch: one DSC frequency + current telephony frequency,
Other facilities:	Built-in self test programme. Continuously operating power and protection monitor.
Supply voltage:	21.6 to 31.2 V DC. With optional external AC Power Supply: 115/230 V AC, 50/60 Hz. Automatic change-over to DC in the absence of AC supply.
Power consumption:	(approx. at 24 V DC) RX, 60 W, TX, SSB unmodulated: 100 W, TX, SSB speech: 175 W, TX, SSB two-tone: 300 W, TX, DSC: 420 W.
Operating temperature range:	-20 deg. C to +55 deg. C.
Equipment category:	Control Unit: Protected, Transceiver Unit: Protected, Antenna Tuning Unit: Exposed.
Compass safe distance:	Compass safe distance in accordance with ISO/R 694 are given below in metres.

Unit	Standard	Steering
	5.4°/H	18°/H
Transceiver Unit	0.4	0.2
Antenna Tuning Unit	0.3	0.1

For Control Unit please refer to Operator's Manual.

DIMENSIONS AND WEIGHTS

Transceiver Unit:	Width: 390 mm
	Height: 445 mm
	Depth: 127 mm
	Weight: 17.5 kg

Antenna Tuning Unit:	Width: 290 mm
	Height: 500 mm
	Depth: 80 mm
	Weight: 3.3 kg

For Control Unit please refer to Operator's Manual.

RECEIVER CHARACTERISTICS

Frequency range:	150 kHz to 30 MHz.
Frequency resolution:	100 Hz by keyboard entry. 10 Hz, 100 Hz or 1 kHz search/fine-tune facility.
Antenna impedance:	50 Ohms. Matched by the antenna amplifier in the antenna tuning unit.
Input protection:	30 V RMS (EMF).
IF selectivity:	SSB telephony: 350 Hz to 2700 Hz, AM broadcast: +/- 3 kHz, DSC: +/- 150 Hz.
Sensitivity:	Antenna input for 10 dB SINAD, 50 ohm antenna. SSB telephony: 0.7 uV, AM broadcast: 4 uV, DSC: 0.3 uV.
Out-of-band intermodulation:	Two 92 dBuV signals more than 30 kHz off tune produces less output than an equivalent input signal of 30 dBuV.
In-band intermodulation:	Less than -40 dB.
Cross modulation:	Unwanted signal of 104 dBuV / 30 % - 400 Hz more than 20 kHz offset from receiver frequency produces cross modulation less than - 30 dB relative to wanted signal of 60 dBuV (SSB).
Blocking:	With a wanted signal of 60 dBuV, an un-wanted signal 20 kHz off tune 110 dBuV will affect the output level by less than 3 dB or cause less than 6 dB reduction in SINAD (SSB).
Reciprocal mixing:	With a wanted signal giving 20 dB SINAD, an unwanted signal 20 kHz off tune and 80 dB above the wanted signal will cause less than 6 dB reduction in SINAD (SSB).
Image rejection:	Greater than 80 dB.
IF rejection:	Greater than 80 dB.
Spurious rejection:	Greater than 80 dB.
Spurious emissions:	Less than 2 nW/50 ohm at antenna connector.
Audio output power:	5 W with less than 10 % distortion.

TRANSMITTER CHARACTERISTICS

Output power:	150 W PEP +/- 1.4 dB into 50 ohm at 24 V supply voltage.
Power reduction:	Low power: approx. 20 W PEP.
Frequency range:	ITU marine bands 1605 kHz to 30 MHz.
Frequency resolution:	100 Hz.
Intermodulation:	Better than -31 dB/PEP in standard two-tone test.
Hum and noise:	Less than - 50 dB/PEP.
Spurious emissions:	Less than -43 dB/PEP, typically better than -60 dB/PEP.
Suppression of unwanted sideband:	Greater than 60 dB PEP (1 kHz, SSB).

DSC MODEM CHARACTERISTICS

Equipment class:	Class B
Protocols:	ITU-R M.493, M.541, and M.1082.
Type of calls:	Distress alert calls, distress relay calls, distress acknowledgement calls, all ships calls, individual station calls including polling and ship position request calls, direct dial semi-automatic/automatic service calls.
DSC message log:	Stores the 20 last received distress calls. Stores the 20 last received non-distress calls. Stores the 20 last transmitted calls. Received calls are erased 48 hours after their reception.
User programmable address book:	Stores 16 calls prepared for transmission.

DSC WATCH RECEIVER CHARACTERISTICS

Frequency:	2187.5 kHz, continuous watch.
Antenna impedance:	50 ohms.
Calling sensitivity:	Antenna input for symbol error rate below 1×10^{-2} : 1 μ V.
Adjacent channel selectivity:	With a wanted signal 20 dBuV, an unwanted signal 500 Hz off tune 60 dBuV does not deteriorate the symbol error rate below 1×10^{-2} .
Co-channel rejection:	With a wanted signal 20 dBuV, an unwanted signal on the same frequency 14 dBuV does not deteriorate the symbol error rate below 1×10^{-2} .
RF intermodulation response:	With a wanted signal 20 dBuV, two unwanted signals more than 30 kHz off tune 70 dBuV does not deteriorate the symbol error rate below 1×10^{-2} .

Interference rejection and blocking immunity:

With a wanted signal 20 dBuV, an unwanted signal in the frequency range 100 kHz to 2 GHz except a +/- 3 kHz band around the tuned frequency 90 dBuV does not deteriorate the symbol error rate below 1×10^{-2} .

Dynamic range:

With a wanted signal between 80 dBuV and 0 dBuV the symbol error rate is below 1×10^{-2} .

Conducted spurious emissions:

Less than 2 nW/50 ohm at antenna connector.

Input protection:

30 V RMS (EMF).

Active antenna supply:

12 V DC, 20 mA available on DSC RX antenna connector, coax inner connector positive.
Short circuit current max 2 mA.

ANTENNA TUNING UNIT**Frequency range:**

1.6 - 30 MHz.

Antenna requirements:

8 - 18 m wire and/or whip antenna.

Antenna tuning:

Fully automatic with no presetting.

Tuning speed:

0.5 - 8 s.

Input impedance:

Nominal 50 ohms.

Power handling capability: 150 W PEP.**INTERFACES FOR EXTERNAL EQUIPMENT****Control Unit connectors****AUX:**

NMEA: Position and time information input: NMEA 0183, RMC, GLL, GGA, ZDA

Alarm Panel: SparcBus interface for optional distress alarm panel.

SW download: PC interface for update of software.

External speaker: AF output for external 4 to 8 ohms loudspeaker.

Transceiver unit connectors**SYS:**

Remote control: RS-232 interface for control of frequency, mode and power level.
Transmitter AF line interface.
Receiver AF line interface.
External key input.

Transmitter inhibition: Input for external inhibition of transmission.

Transmitter keyed indication: Output for external indication of transmission.

SUPPLY ALARM:

Battery alarm: Voltage input for high/low battery voltage alarm.
Alarm in case of

- Battery voltage too low (adjustable 22-24 V).
- Battery voltage too high (adjustable 27-32 V).

Factory preset to 23.5 V and 29.5 V.

AC alarm: Input for supply failure alarm.
Alarm when connected to GND.

CONTENTS

2	INSTALLATION	2-1
2.1	DESCRIPTION	2-1
2.2	MOUNTING THE UNITS	2-1
2.3	GROUND CONNECTIONS	2-5
2.4	GROUNDING CONSIDERATIONS	2-5
2.5	ANTENNAS	2-7
2.6	POWER SUPPLY	2-10
2.7	INTERCONNECTION OF UNITS	2-10
2.8	CONNECTOR MOUNTING INSTRUCTIONS	2-15
2.9	POSITION AND TIME INFORMATION	2-16
2.10	OPTIONS MENU - SETTING UP THE SYSTEM	2-16
2.11	DSC PROGRAMMING	2-17
2.12	BATTERY ALARM ADJUSTMENT	2-18
2.13	FACTORY RESETTING	2-18
2.14	FINAL INSTALLATION CHECK	2-18

2 INSTALLATION

2.1 DESCRIPTION

Correct installation of the equipment is important for maximum performance and reliability. Antennas and earth connections must be installed with the greatest care using corrosion resistant materials. Cable routing shall be made so the cables are protected from physical damage. Sharp cable bends especially on coaxial cables must be avoided and a sufficient number of clips or straps should be used to secure the cables.

2.2 MOUNTING THE UNITS

Mounting the Control Unit (CU)

One Unit shall be connected to the Transceiver Unit using the build-in local area network (ScanBus). The CU may be mounted up to 100m from the Transceiver Unit using just one Multicable 5 x 2 x 0.5 mm² screened.

For detailed installation and mounting of CU - see Operator's Manual.
The Control Unit may be tabletop or bulkhead mounted.

Control Units with Mounting Bracket - dependent of ordered type

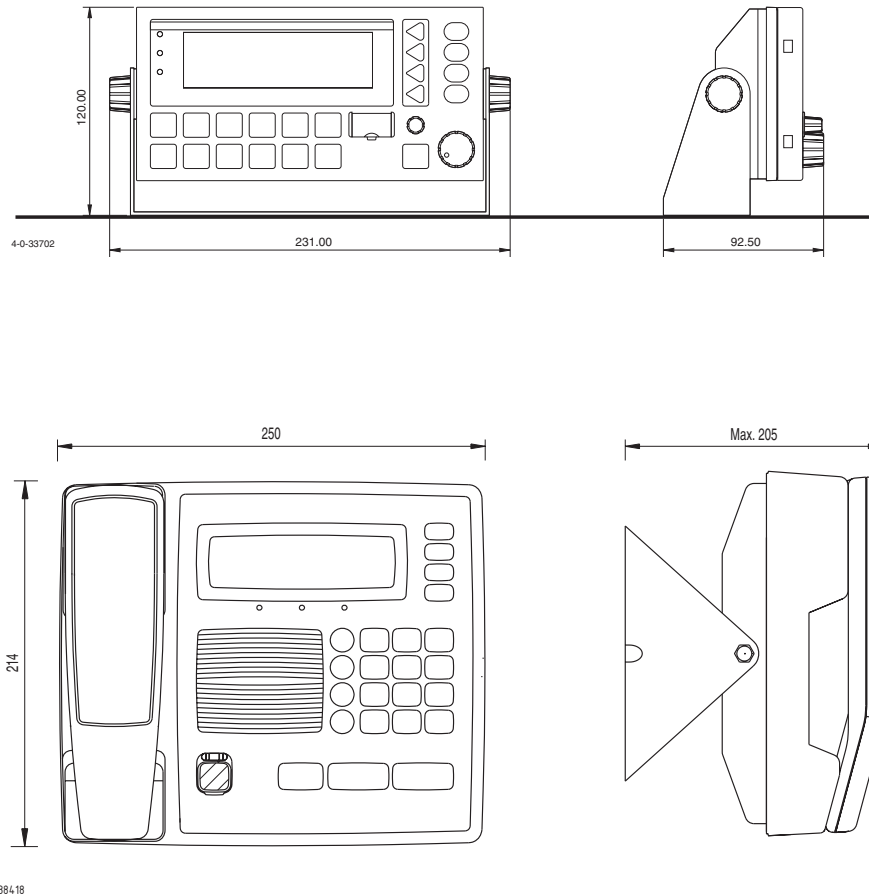

Dimensions are in mm

Mounting the Transceiver Unit (TU)

The Transceiver Unit should be installed in a dry place and consideration should be given to accessibility for servicing. It is important to provide sufficient airspace below, above and in front of the unit for adequate air circulation through the cooling fins. The drawing below shows the outer dimensions, mounting possibilities and the minimum distance to other objects, as well as a drilling plan.

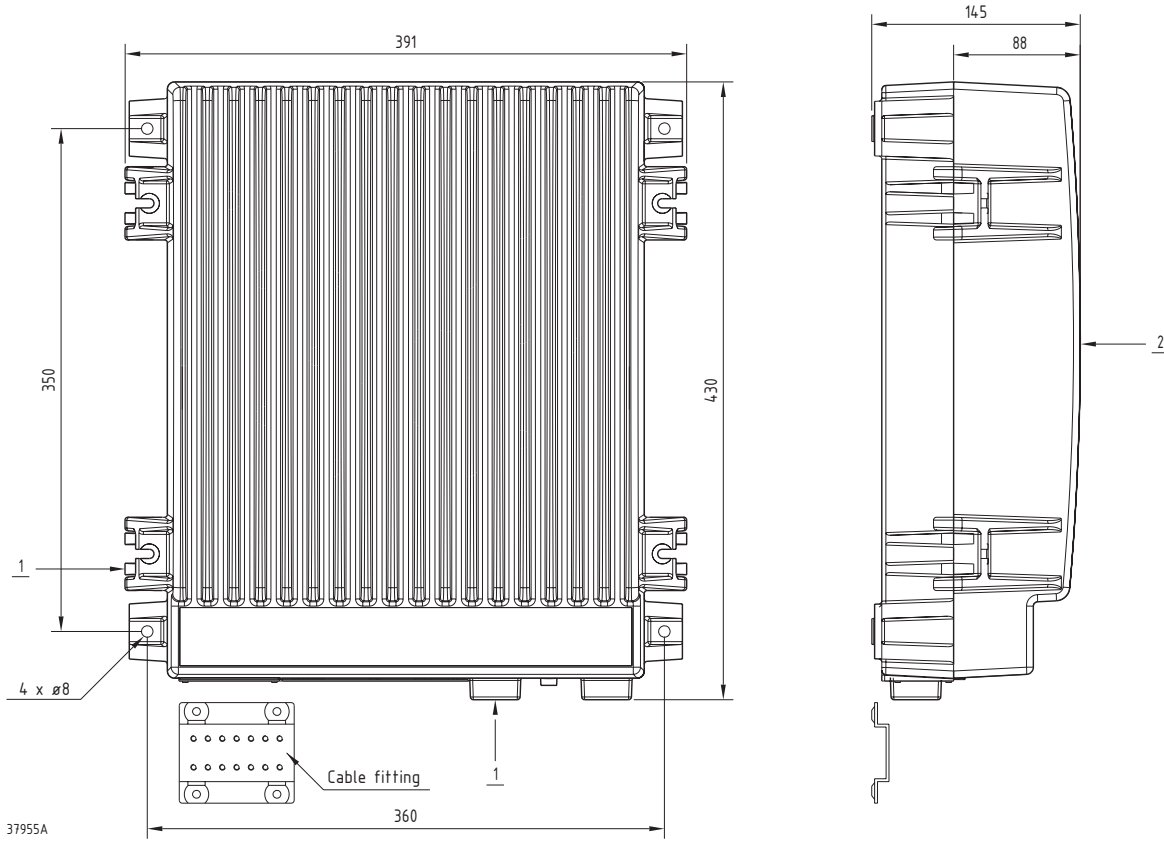

- 1) Space for cable: min. 150 mm
- 2) Space for airflow and service: min. 500 mm

Cable fitting

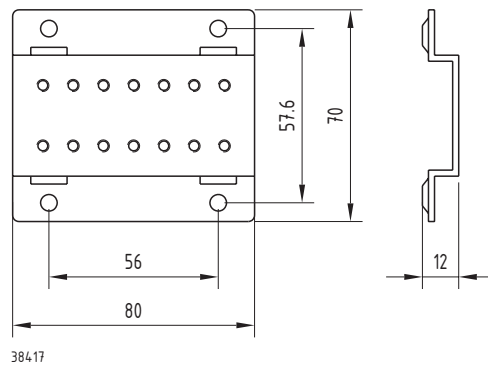

Dimensions are in mm

Mounting the Antenna Tuning Unit (ATU)

The Antenna Tuning Unit may be mounted up to 100 metres from the Transceiver Unit using just one RG-213/U coaxial cable. The unit should be installed near the antenna feed point.

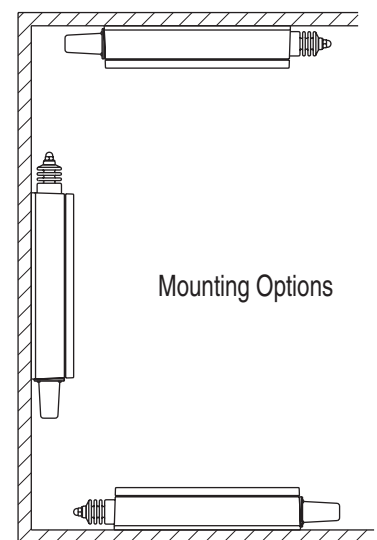
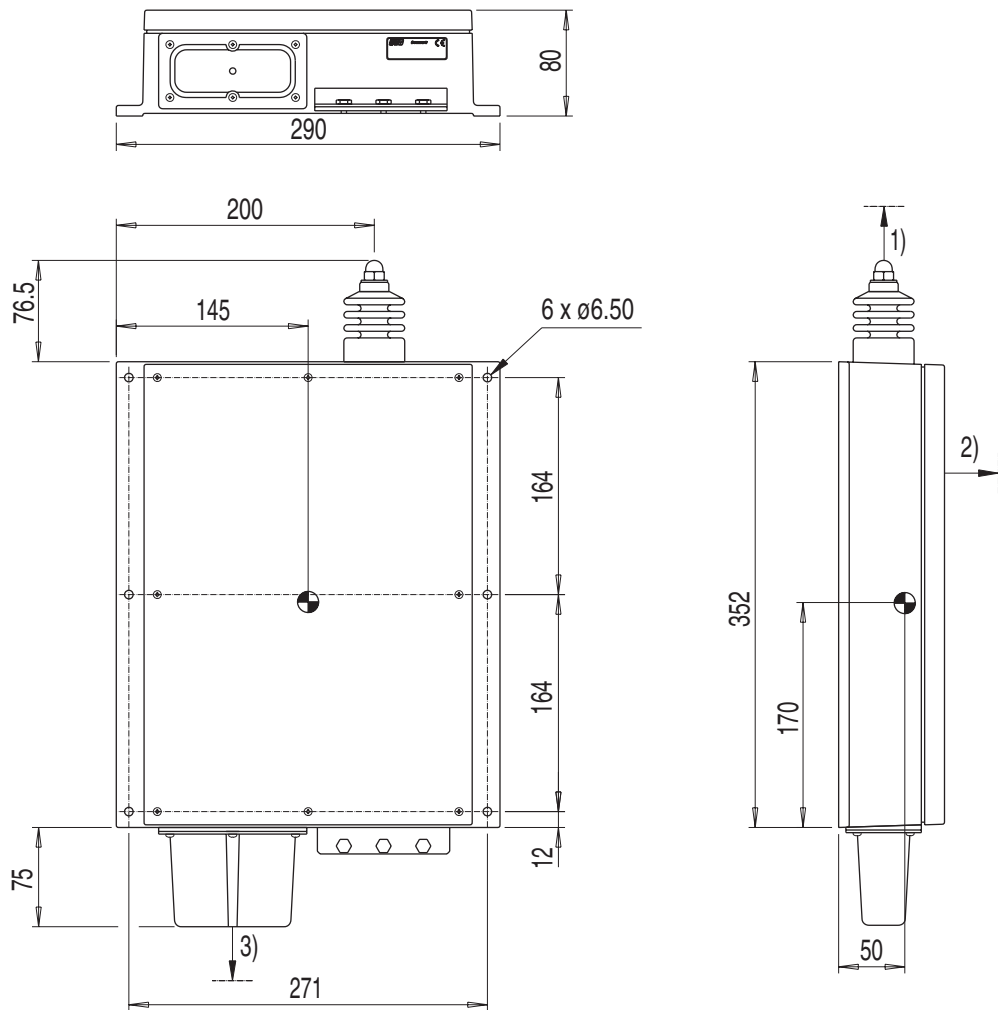

37978

- 1) Space to nearest overhang: min. 50 mm
 - 2) Space for service access: min. 500 mm
 - 3) Space for cable and service access: min. 200 mm
- Dimensions are in mm

CB4616 Terminal Block Converter Box (accessory)

CB4616 is used to convert the rather small DSUB-9 to a screw terminal with strain relief for large cables such as veritas cables. This box is delivered with a 1m DSUB-DSUB cable for connection to CU or TU.

Drilling Plan

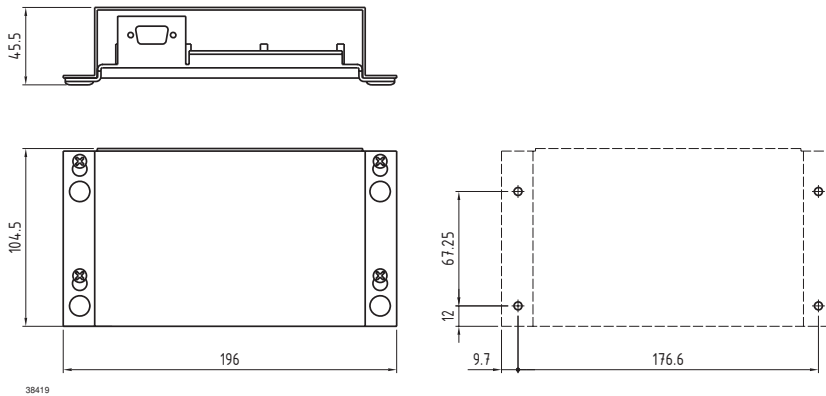

Weight:
CB4616 0.6 kg.

CB4618 Handset Connection Box (accessory)

CB4618 is used to connect the scrambler CRY2001 or to interface a secondary handset or the Heavy Duty Handset.

Drilling Plan

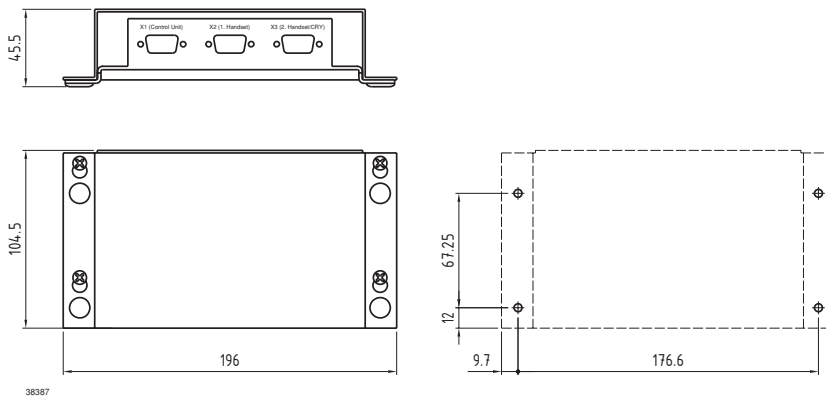

Weight:
CB4618 0.6 kg.

Dimensions are in mm

CB4616 and CB4618 may be ordered as accessory. Please find accessory list on the last page of this manual.

2.3 GROUND CONNECTIONS

Antenna Tuning Unit

As the earth connection of a transmitter is a very important part of the antenna system, it is of the utmost importance to keep in mind that the earth connection of the Antenna Tuning Unit must have the lowest possible RF-impedance. Losses in the earth connection will result in a decrease in radiated power which means that the range of the transmitter will be reduced. In steel ships a 100 x 0.5 mm copper strap as short as possible is connected between the earth terminal at the bottom of the Antenna Tuning Unit and two or three 1/2" or M12 bolts welded to the superstructure. Vessels constructed of non-conducting materials must be equipped with a copper earth plate having a minimum area of 1 square metre mounted below the water line. From a copper earth bolt hard soldered to the earth plate a 100 x 0.5 mm copper strap is run, preferably uninterrupted to the earth terminal at the bottom of the Antenna Tuning Unit.

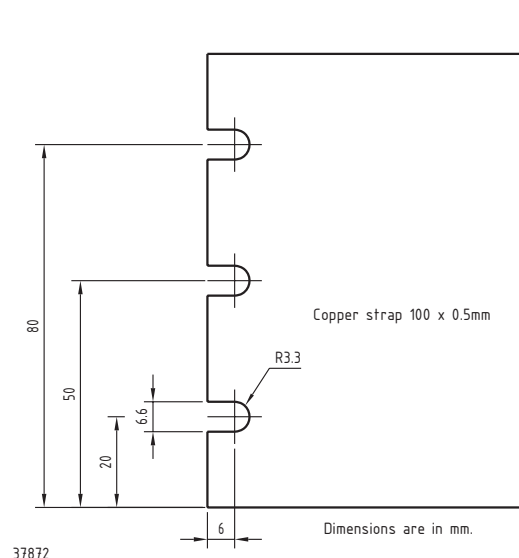

Should it be necessary to break the copper strap, for example to pass through a deck, two or three 1/2" or M12 bolts should be used for this feed through. On wooden ships having a superstructure of metal, this superstructure should also be effectively connected to the copper strap by using stainless steel bolts and preferably pieces of stainless steel strips between the metal parts. On fibre glass boats, such as yachts and sailing boats, it may be difficult to install a sufficiently good earth. Short copper straps are bolted to conducting parts on the engine, the keel and other conducting objects. Many copper straps can be glued to the inner surface of the hull below the water line to produce a large capacitance to the water. It is important that the total area of copper is large and that the distance between the copper surface and the water is as small as possible. The copper straps are connected directly to the ATU.

Transceiver Unit and Control Unit

The Transceiver Unit is preferably grounded separately to the ships metal in the shortest possible way. A 10 to 16mm sq. ground wire is connected to the ground terminal (cable clamp) at the bottom of the unit.

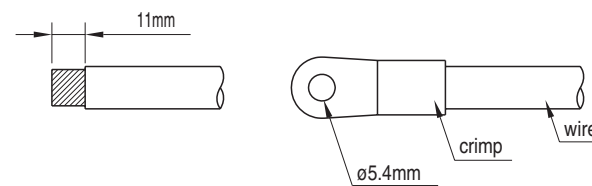

2.4 GROUNDING CONSIDERATIONS

Proper system grounding is one of the most important installation details. Two areas of grounding must be considered:

- a) The ground connection between the ATU and earth ground plane.
- b) The ground connection of the TU and the externally connected equipment.

Each area requires separate considerations even though they are interrelated. Ideally the Control Unit, Transceiver Unit, Antenna Tuning Unit and the antenna ground-plane must have the same RF ground potential. Unfortunately this situation is seldom achieved, but interference problems will be reduced along with how close to this "ideal" the grounding of the installation is performed.

On some installations ground loops will cause problems. A ground loop is caused by more than one ground path for a given unit. This will introduce circulating RF currents which may cause malfunction of other equipment onboard the ship as well as a "hot" handset.

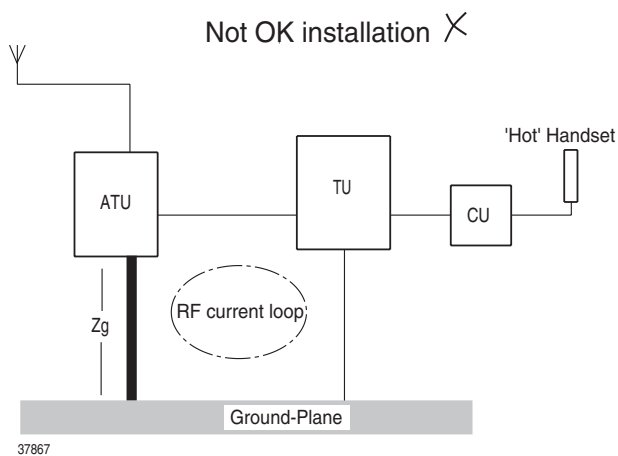

Antenna start

The vertical antenna always start at its electrical ground-plane, whether or not it is physically mounted there. First determine the antenna's electrical ground-plane, which is where the ATU must be mounted. Where possible always take the ATU to the ground, not the ground to the ATU. In case of a fiberglass boat, the ground-plane may well be at the hull grounding terminal. Then this is where the Antenna Tuning Unit should go and this is where the antenna actually starts.

OK installation ✓

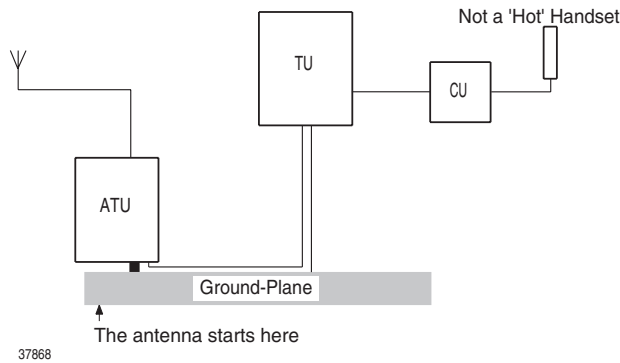

RF ground loop

It is not always possible or practical to mount the ATU using a very short strap to the actual ground-plane. In such a case the coaxial cable may be connected between units with different ground potentials causing RF loop-current to flow.

Not OK installation ✗

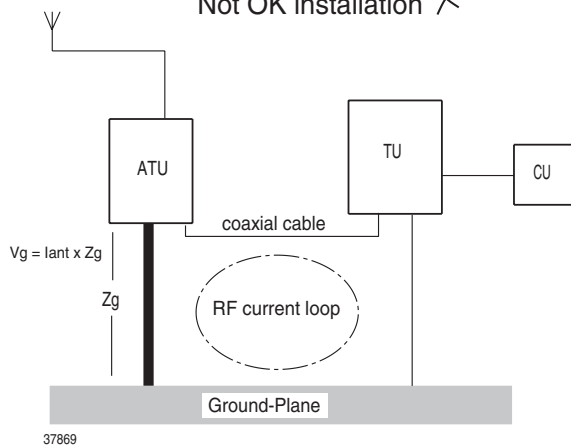

Minimizing ground loops

By routing the coax cable very close together with the ATU ground strap (secure good RF coupling between the two) all the way down to the ground-plane, there will be no RF ground loop left to generate the interference.

OK installation ✓

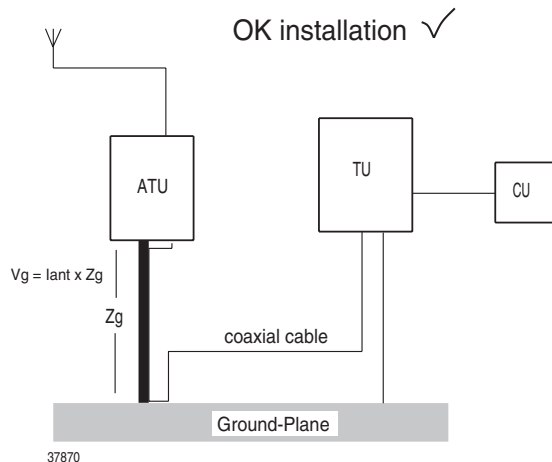

2.5 ANTENNAS

Transceiver Antenna

The equipment is used with common transmitting and receiving antenna. The antenna should be erected in the open, away from conducting object such as derricks etc. which may cause reduction of the radiated power. Insulators should be of the best type having low leakage even when wet. Stays, wires, steel masts etc. should be either effectively earthed or insulated. The antenna should also be kept as far away as possible from electrical equipment in order to minimize noise. Electrical installation such as cable braiding (screens) and instruments in the vicinity of the antenna should be earthed effectively, and the instruments in question should be fitted with noise-interference suppression devices, effective in the range 0.1 MHz to 30 MHz to avoid malfunction of these instruments. The Antenna Tuning Unit will tune on any frequency in the range 1.6 to 27 MHz to good whip and/or wire installations of 12 to 18 meters total electrical length. Shorter antennas, electrical length down to 8 meters can be used. Where possible long antennas should be installed to maximize the radiated power in the lower frequency bands.

In general a 12 meter antenna installation can be made using an 8 meter whip and 4.5 meter feeder or a 10 meter whip and 2.5 meter feeder. In both cases the whip should be mounted on a pole allowing for the feeder to be erected at an angle of no less than 60 degrees to create a vertical antenna system. Using horizontal feeders or feeders mounted at an angle below 45 degrees usually transform the antenna radiation resistance to a lower value reducing the radiated power. Furthermore, the total antenna system should be kept well away from conductive objects such as the mast. Usually a horizontal distance of more than 4 meters will create good results.

Note: If a whip antenna is used this should have an anti-corona ball as a top termination to prevent crackling noise in the receiver.

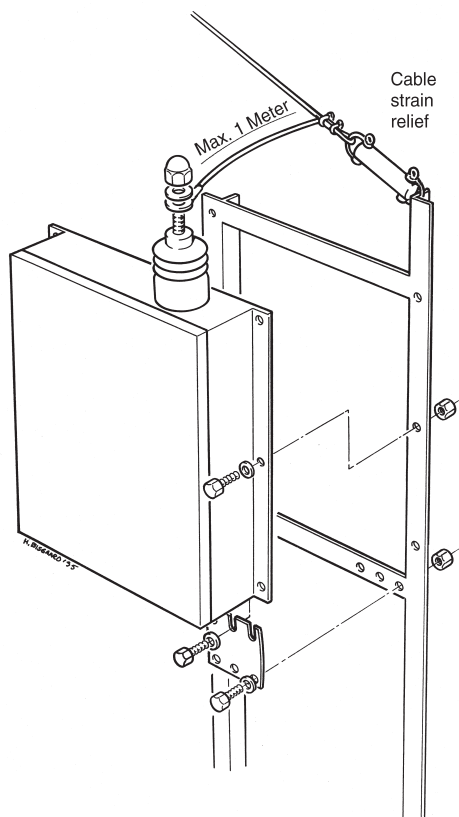

The antenna is terminated at the insulator at the top of the Antenna Tuning Unit. The insulator must be relieved from mechanical stress by using max. 1 metre flexible wire between the insulator and a support. To maximize the radiated power and avoid flash over keep distance to metal parts as long as possible. All wire junctions in the antenna system must be made with cable lugs of correct size according to the wire gauge. This will prevent bad connections due to corrosion. For further corrosion proofing grease may be applied to the cable joints.

Recommended ATU installation

On a metal-hull vessel. Mount the Antenna Tuning Unit on a custom-built bracket made from iron angle bars (refer to figure on previous page).

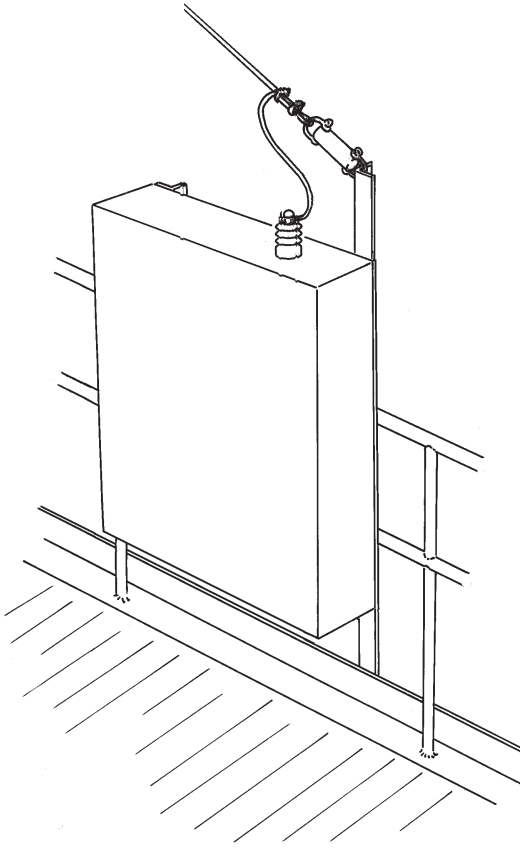

Antenna Tuning Unit bracket
welded to the railing.

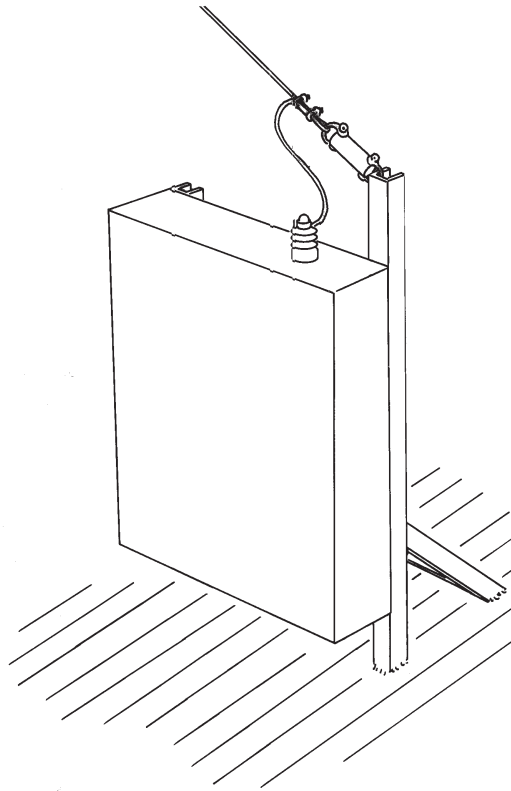

Antenna Tuning Unit bracket
welded to the deck.

Optional an ATU Mounting Kit may be supplied as shown below. The kit exists in two versions:

- | | | |
|---|--|-----------------|
| 1 | Includes mounting plate and fittings for mast. | Part no. 737589 |
| 2 | Includes the mounting plate. | Part no. 737588 |
-
- 1 For mounting the ATU directly on a mast, where the Mounting Plate and fittings for mast can form a sufficient earth connection on a steel mast welded to the superstructure.
 - 2 To get an even mounting surface on an uneven support.

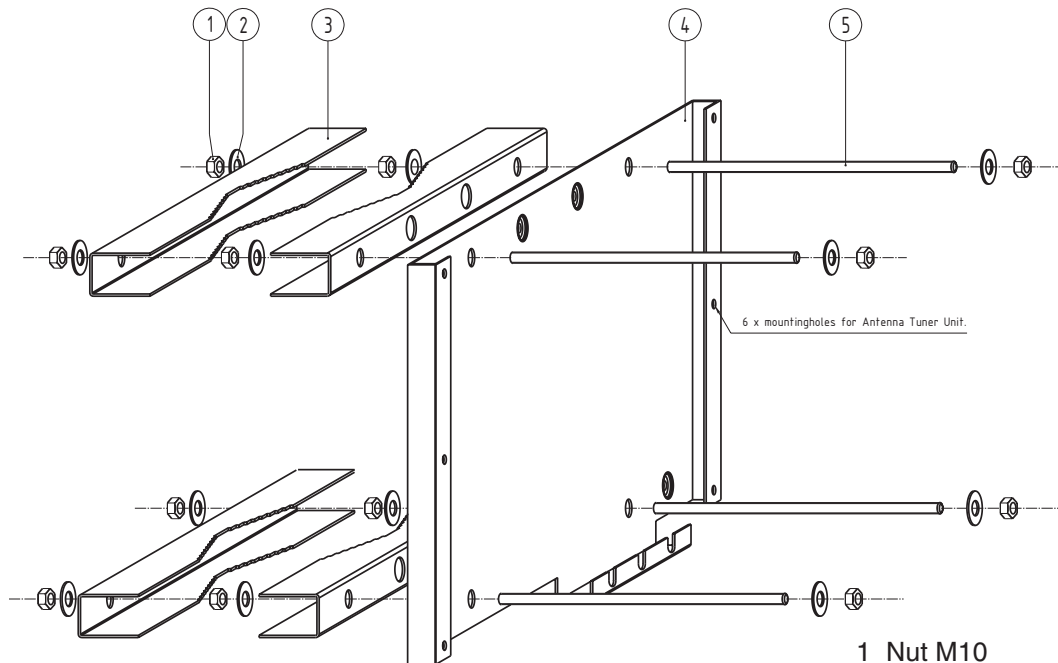

- 1 Nut M10
- 2 Tooth lock washer M10
- 3 Fitting for mast
- 4 Mountingplate for ATU
- 5 Treadrod M10

DSC watch receiver antenna

The DSC watch receiver antenna may be an active or a passive type.

The antenna should be erected well in the clear and kept away as far as possible from electrical equipment in order to minimize noise. Electrical installation such as cable braiding and instruments in the vicinity of the antenna should be earthed effectively, and the instruments in question should be fitted with noise-interference suppression devices, effective in the range 0.1 to 30 MHz. The antenna feed-in should be coaxial cable.

In case of a passive antenna the feed-in should be as short as possible, especially in the case of short antennas. The recommended antenna length is 7-30 meters. If a long coax cable is necessary an impedance matching transformer should be inserted at the antenna or an active antenna should be used. DC supply voltage for an active antenna is available at the DSC RX antenna connector. The supply voltage is +12 V for supply currents up to 20 mA. The short circuit current is limited to 2 mA to allow passive antennas with matching transformers to be connected directly.

2.6 POWER SUPPLY

The supply leads are connected to the supply terminal strip of the Transceiver Unit. The supply terminal strip is adapted for screened power supply cable to meet EMC requirements. The screen of the cable is connected to the left terminal.

The earth connection of the equipment will not cause the battery to be earthed. Maximum permissible peak voltage between the battery terminals and earth is 100 V. Note that fuses must be provided in the supply leads. Table below shows the necessary cable cross sections and external fuse ratings.

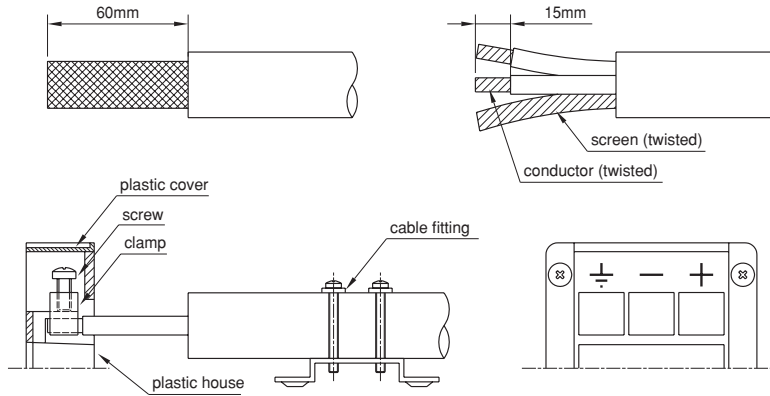

37835

Max. cable length to battery *	Recommended cable Screened multiwire	External fuses
7 m	2 x 10 mm ²	40 A
11 m	2 x 16 mm ²	50 A
17 m	2 x 25 mm ²	63 A

2.7 INTERCONNECTION OF UNITS

Transceiver Unit connector panel

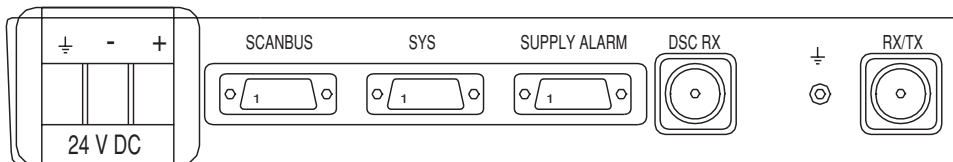

37849

For Control Unit connector panel please refer to Operator's Manual.

Cable 1: Handset - Control Unit

Cable: Supplied with handset

Control Unit 'HANDSET' Dsub 9	Designation	Remarks
1	TLF	Handset earpiece
2	GND	System ground
3	GND	System ground
4	MIC	Handset microphone
5	PTT	Transmit key
6	HOOK	Low when on hook
7	+5V	5 V supply to handset
8	nc	No connection
9	2182 SEL	OC output. Low when 2182 kHz is selected

Cable 2: Control Unit - GroundRecommended wire dimension: min. 2.5 mm²

Maximum length 0.2 m

Cable 3: Control Unit - Transceiver UnitCable: Multicable 5 x 2 x 0.5 mm² screened

Maximum cable length 100 m

Cable-connector: 9 way Dsub male. Part no. 75100064

Twisted pairs	Control Unit 'SCANBUS' Dsub 9	Transceiver 'SCANBUS' Dsub 9	Designation	Remarks
	1	1	SUPPLY ON	Supply on signal to the Transceiver Unit. Active when connected to GND
1	2	2	DATA+	Data communication between units. CAN bus. Baud rate: 125 kbps
	3	3	DATA-	Spec.: ISO/DIS 11898.
2	4	4	AF +	TX AF modulation
	5	5	AF -	Vnom = 0.775 Vrms diff. Vmax = 12 Vpp diff.
	6	6	GND	System ground
	7	7	+24 V	Supply voltage for the Control Unit.
3	8	8	RX AF +	RX AF signal
	9	9	RX AF -	Vnom = 0.775 Vrms diff. Vmax = 12 Vpp diff.
	Shield	Shield	Screen	Screen connected to system ground

Cable 4: Transceiver Unit - Antenna Tuning Unit

Cable: 50 ohm coaxial cable RG213/U part no.: 77.508

Maximum cable length 100 m

Cable-connector: UHF connector PL259. Part no. 75100054

Cable 5: Transceiver Unit - GroundRecommended wire dimension: min. 10 mm²

Maximum length 0.2 m

Cable 6: Transceiver Unit - DSC RX Antenna

Type: 50 ohm coaxial cable RG213/U part no.: 77.508

Maximum cable length 100 m

Cable-connector: UHF connector PL259. Part no. 75100054

Cable 7: Antenna Tuning Unit - Ground

Copper strap 100 x 0.5 mm

Refer to section 'Ground Connections'

Cable 8: Control Unit - External SpeakerCable: Multicable 2 x 0.5 mm² screened

Maximum cable length 3m

Control Unit 'AUX' pins 5 and 9. Refer to 'AUX' table.

Cable 9: Control Unit - GPSCable: Multicable 2 x 0.5 mm² screened

Control Unit 'AUX' pins 4 and 8. Refer to 'AUX' table.

Cable screen should be connected to the GPS chassis only and not be connected to system ground.

Cable 10: Control Unit - External Distress Alarm PanelCable: Multicable 4 x 0.5 mm² screened

Maximum cable length 100 m

Cable-connector: 9 way Dsub male. Part no. 75100064

Control Unit	Designation	Remarks	Alam Panel
AUX Dsub 9			MF/HF x4 Dsub 9
1	SPARC-BUS+	To Distress Alarm Panel	3
2	DATA OUT	RS-232 port for SW upload	
3	DATA IN		
4	NMEA IN-	NMEA position input	
5	GND	System ground	2
6	SPARC-BUS-	To Distress Alarm Panel	5
7	+24 V	To Distress Alarm Panel	9
8	NMEA IN+	NMEA position input	
9	EXT_SP+	External speaker	
Shield	Screen	Screen connected to system ground	

Cable 11: Control Unit – External DSC AlarmsCable: Multicable 4 x 0.5 mm² screened

Maximum cable length 3 m

Cable-connector: 25 way Dsub male. Part no. 75100066

Control Unit	Designation	Remarks
'ALARM' Dsub 25		
1	DISTRESS ALARM	Standard HC-MOS output +5 V when active
2	nc	No connection
3	OTHER DSC ALARM	Standard HC-MOS output +5 V when active
4-16	nc	No connection
17-25	GND	System ground
Shield	Screen	Screen connected to system ground

Cable 12: Transceiver Unit – 24 V Battery

Max. cable length to battery	Cable type	External fuses
7 m	2 x 10 mm ² screened	40 A
11 m	2 x 16 mm ² screened	50 A
17 m	2 x 25 mm ² screened	63 A

Cable 13: Transceiver Unit – AC power supplyCable: Multicable 4 x 0.5 mm² screened

Cable-connector: 9 way Dsub male. Part no. 75100064

Transceiver Unit 'SUPPLY ALARM' Dsub 9	Designation	Remarks
1	nc	No connection
2	nc	No connection
3	nc	No connection
4	/AC ALR	AC Alarm input. Alarm when connected to GND
5	GND	System ground
6	VBAT-	Voltage input for high/low battery voltage alarm
7	VBAT+	
8	nc	No connection
9	nc	No connection
Shield	Screen	Screen connected to system ground

Cable 14: Transceiver Unit – TX InhibitCable: Multicable 2 x 0.5 mm² screened

Maximum cable length 3 m

Transceiver Unit 'SYS' pins 4 and 5. Refer to 'SYS' table.

Cable 15: Transceiver Unit – Data modemCable: Multicable 4 x 0.5 mm² screened

Maximum cable length 3 m

Cable-connector: 9 way Dsub male. Part no. 75100064

Transceiver Unit 'SYS' Dsub 9	Designation	Remarks
1	EXT KEY	Transmitter key input. Pulled up to Active when connected to GND
2	DATA OUT	RS-232 port for remote control of frequency, mode and power level. T+Bus protocol, baud rate 2400 bps. Also used for upload of software.
3	DATA IN	
4	TX INHIBIT	Transmitter inhibit input. Pulled to +12 V Active when connected to GND
5	GND	System ground
6	LINE OUT	Single ended 600 ohms AF output 0 dBm in 600 ohms 1.55 Vrms when unloaded Refers to system ground (GND)
7	LINE IN	Single ended 600 ohms AF input Nominal level 0 dBm Accepts -15 dBm to +10 dBm Refers to system ground (GND)
8	TX KEYED	Low when TX keyed OC output, max. 50 mA, 32 V
9	+12 V	+12 V output Max. 100 mA, internally protected.
Shield	Screen	Screen connected to system ground

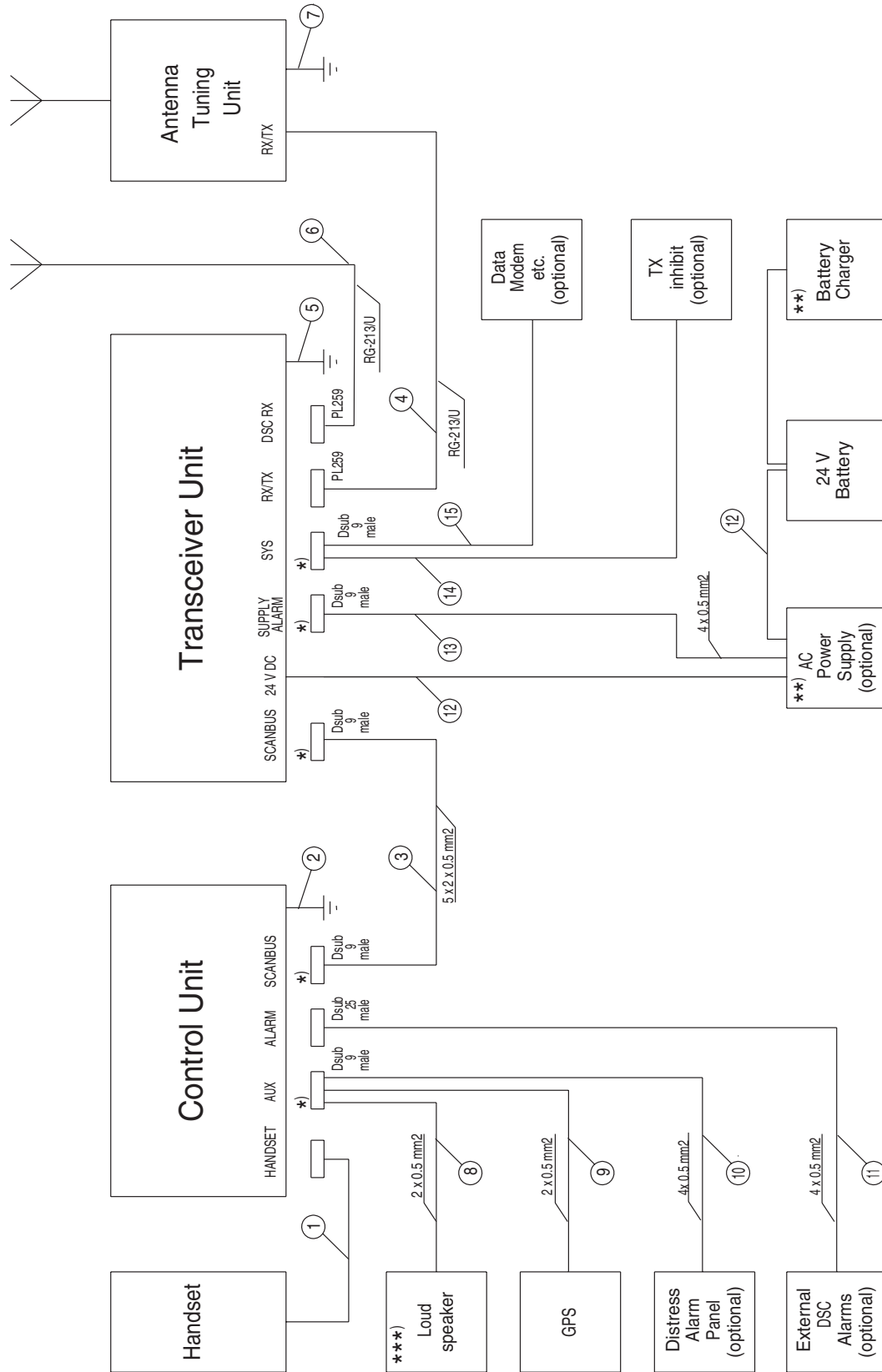

* Please check the accessory list to find the optional DSUB to screw Terminal Converter Box CB4616.

** Please check the accessory list to find recommended power products.

*** Please check the accessory list to find recommended loudspeaker.

Please note that for distance less than 25m the system will work with 0.25mm² instead of 0.5mm².

2.8 CONNECTOR MOUNTING INSTRUCTIONS

9 and 25 way D-sub

15 mm - 9 way D-sub
30 mm - 25 way D-sub

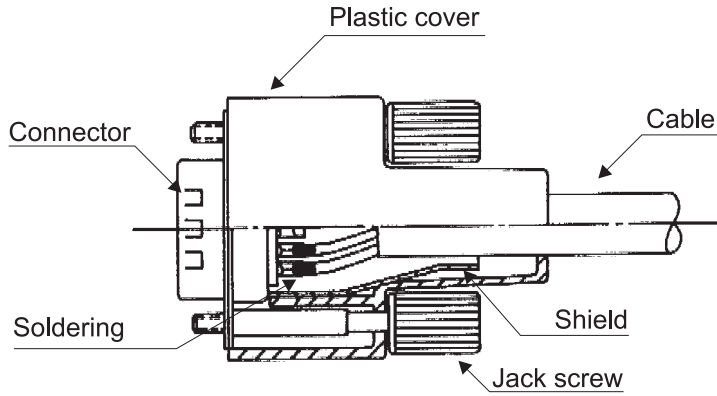
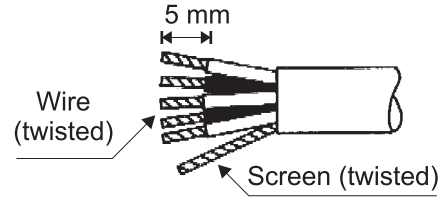
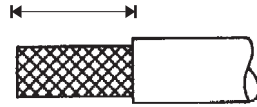

Slide the plastic cover on the cable before the wires are soldered to the pins.

After the pins are soldered; latch the inner and outer shield into the connector and snap in. Finally slide the plastic cover over the shield and fit the two jack screws into the cover.

Contact arrangement
(Viewed from solder side)

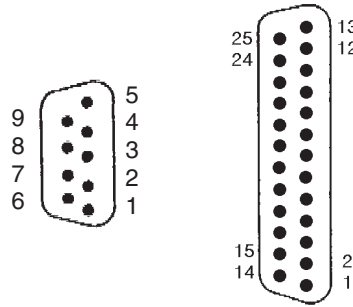

PL 259

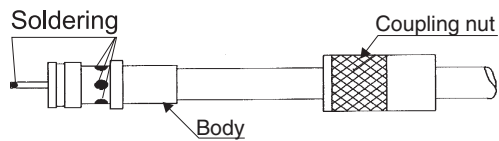

2.9 POSITION AND TIME INFORMATION

Connection of Navigation Equipment

Navigation equipment complying with the NMEA 0183/IEC 1162 standard may be connected for automatic position and time updating. Connection is made to the 'NMEA' terminals of the Control Unit. The NMEA receive circuit consists of an optoisolator with a 470 ohms series resistor to insure current mode operation and a shunt diode to limit reverse bias as shown below. The circuit is isolated from ground.

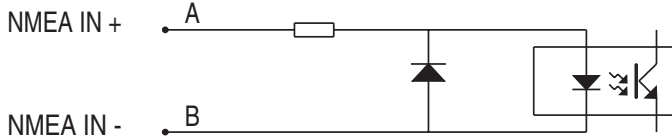

The circuit operates with a minimum differential input voltage of 2 volts and takes less than 2 mA from the line at that voltage. The maximum voltage is 15 volts.

37871

Interconnection between devices may be by means of two-conductor shielded twisted-pair wire. Multiple listeners may be connected to a single talker. The receivers are connected in parallel. The shield should be connected to the navigator chassis and should **not** be connected at any listener. However the shield should be continuous (unbroken) between all listeners.

Following sentences are recognized by the equipment for extraction of position and associated time information: RMC, GLL, GGA. GLL sentences with and without time information is recognized, time information is extracted if present.

ZDA, RMC, GLL and GGA sentences are recognized by the equipment for extraction of UTC time information for automatic setting of the internal real time clock.

2.10 OPTIONS MENU - SETTING UP THE SYSTEM

To open the Options menu, press FUNC and select 'OPTIONS' in the 'SETTINGS' menu and enter the access code,1,2,3,4.

Menu	Submenu Level1	Submenu Level 2	Submenu Level 3 / Parameters		
OPTIONS	TX BANDS	EDIT Select band	Edit TX frequency band		
	CONFIGURATION	LSB MODE, REMOTE MODE, BATTERY ALARM, ATU INSTALLED	Enable/disable		
	DSC	LANGUAGE	Select language		
		RX TEST	Enable/disable serial output of decoded DSC calls for test purposes		
		TX TEST	SEND DOTS	SEND DOTS	Send dot Pattern
			SEND Y	SEND Y	Send Y frequency (1615 Hz)
	SEND B		SEND B	Send B frequency (1785 Hz)	

Notes:

TX Bands: Up to 16 frequency bands can be defined. Transmission is inhibited on frequencies outside the defined bands.

Factory pre-programmed:	1605.0	-	4000.0	kHz
	4000.0	-	4438.0	kHz
	6200.0	-	6525.0	kHz
	8100.0	-	8815.0	kHz
	12230.0	-	13200.0	kHz
	16360.0	-	17410.0	kHz
	18780.0	-	18900.0	kHz
	19680.0	-	19800.0	kHz
	22000.0	-	22855.0	kHz
	25070.0	-	25210.0	kHz
	26100.0	-	26175.0	kHz

Configuration:

- LSB mode: When enabled selection of LSB (Lower Side Band) is possible with the MODE key on the front panel.
Note: LSB mode is normally not allowed for marine equipment.
 Factory default setting: Disabled.
- Remote mode: When enabled selection of SSB REMOTE is possible with the MODE key on the front panel, allowing remote control via the SYS connector of frequency, mode and power level.
 Factory default setting: Disabled.
- Battery Alarm: When enabled the voltage at the VBAT input of the SUPPLY ALARM connector is monitored and an alarm is given by the Control Unit if the voltage is outside the set range.
 Factory default setting: Disabled.
- ATU installed: When enabled supply voltage and control signals for the ATU is present at the TX/RX connector. When disabled a 50 ohms antenna or dummy load may be connected to TX/RX.
 Factory default setting: Enabled.
- DSC:**
- Language: Factory default setting: English.
- RX test: When enabled decoded call sequences are routed to the RS-232 port of the SYS connector. Baud rate: 2400 baud. Parity/data bits: Odd/8.
 Factory default setting: Disabled.
- TX test: For generation of continuous B or Y signal and dot pattern. DSC mode must be selected.

2.11 DSC PROGRAMMING**Programming of DSC self-identification**

The Maritime Mobile Service Identity (MMSI) assigned to the station must be stored in the DSC modem before it can be used on board the ship. The MMSI number will be requested each time the equipment is switched on until it has been stored.

Key in the MMSI number of the ship. Check the number carefully and select 'ENTER'. After the MMSI number has been entered it is necessary to restart the system to effect the change: Switch supply off and on. Check the MMSI number by selecting FUNC, 'INFO & TEST', 'INFORMATION', 'MMSI' and read the number.

Once the MMSI number has been stored in the DSC modem, change of self-identification is not possible (only after a factory resetting).

Programming of DSC group-identification

Six different group identities may be assigned to the station. Group call identity numbers always contain a leading zero. The group call identities must be stored in the DSC modem before it is able to respond to group calls.

Select FUNC FUNC, 'INFO & TEST', 'INFORMATION', 'MMSI', 'EDIT GROUP'. Key in the group call identities and select 'OK'.

2.12 BATTERY ALARM ADJUSTMENT

Connect a voltmeter and an external power supply capable of delivering 1.0 A and adjustable up to 33 V DC to the VBAT- and VBAT+ input of the SUPPLY ALARM connector on the Transceiver Unit. Open the Transceiver Unit to gain access to the potentiometers on Control/Interconnection Module 636510.

Low voltage alarm

1. Adjust the external power supply to the desired low voltage alarm level (22 – 24 V).
2. Watch the Alarm LED.
3. Now carefully turn the potentiometer marked 'Batt. low adj.' until the light in the Alarm LED just disappears.

Factory setting: 23.5 V

High voltage alarm

1. Adjust the external power supply to the desired high voltage alarm level (27 – 32 V).
2. Watch the Alarm LED.
3. Now carefully turn the potentiometer marked 'Batt. high adj.' until the light in the Alarm LED just disappears.

Factory setting: 29.5 V

2.13 FACTORY RESETTING

1. Switch supply off.
2. Insert factory resetting plug (see below) in Control Unit ALARM connector.
3. Switch supply on.
4. The Control Unit indicates 'Factory Reset' and requests MMSI number.
5. Remove factory resetting plug.

All programmable parameters are now reset to the factory default values.

Factory resetting plug: Pin 9 + 13 and pin 8 + 11 shorted. If pin 8 + 11 is shorted only MMSI is reset.

2.14 FINAL INSTALLATION CHECK

For operation of the equipment please refer to the Operator's Manual.

Check the hardware configuration of the transceiver by selecting FUNC and the 'INFO & TEST', 'INFORMATION' 'HW VERSION' menu items, in particular check that the Antenna Tuning Unit is recognized, if installed.

Perform a Self Test of the transceiver by selecting FUNC and the 'INFO & TEST', 'CHECK', 'SELFTEST' menu items. The self test is performed automatically and is used for verification of all functions. Check the transmitter in all marine bands.

The Antenna Tuning Unit will tune automatically to the antenna first time the equipment is keyed on a new frequency or when the TUNE button is pressed. During the tune sequence and normal transmission all transmitter circuits are monitored to ensure safe operating conditions. If transmission conditions are bad (bad antenna installation, high temperatures, etc.) the transmitted power will be reduced to a safe limit. If the transmission condition is improved automatic recovery to full power takes place.

The protection can be investigated by selecting FUNC and the 'INFO & TEST', 'CHECK', 'TX PROTECTION' menu items. The displayed protection code(s) is described in the Service chapter of this manual.

If a GPS is connected, check position and time in the DSC Status display.

If time is not contained in the NMEA sentences the time of position is indicated as —:—. In this case check if the GPS output setting can be changed to allow time information. Otherwise UTC time must be entered manually each time the transceiver is switched on.

Send a DSC test call to the appropriate coast station. The acknowledgement from the coast station is received by the 2187.5 kHz watch receiver if the call was sent on that frequency. If the call is sent on HF only the audio signal output from the 2187.5 kHz watch receiver should be checked by selecting FUNC and the 'INFO & TEST', 'MONITOR', 'WR AUDIO' menu items.

CONTENTS

3	TECHNICAL DESCRIPTION	3-1
3.1	CONTROL UNIT	3-1
3.2	TRANSCEIVER UNIT	3-1
3.3	CONTROL / INTERCON MODULE 636510	3-1
3.4	SYNTH. AND DSC WR MODULE 636511	3-1
3.5	RX/EX SIGNAL PATH MODULE 636515	3-2
3.6	PA AND FILTERS MODULE 636520	3-2
3.7	SMPS MODULE 636530	3-2
3.8	TRANSCEIVER UNIT BLOCK DIAGRAM	3-3
3.9	TRANSCEIVER UNIT INTERCONNECTION DIAGRAM	3-4
3.10	ANTENNA TUNING UNIT	3-5
3.11	ANTENNA TUNING UNIT BLOCK DIAGRAM	3-5
3.12	POWER CONTROL AND PROTECTION SYSTEM	3-6
3.13	POWER CONTROL AND PROTECTION SYSTEM	3-7

3 TECHNICAL DESCRIPTION

3.1 CONTROL UNIT

The control unit consists of a main module, a display module and a keyboard module.

The main module consists of the digital part, i.e. the microprocessor, program FLASH PROM, configuration FLASH PROM, RAM, ScanBus data communication driver, SPARC-Bus driver. The main module also consists of an analog part, i.e. the voltage regulators, the analog interface circuits and the analog output drivers (audio and light). The main module contains the encoder and the potentiometer.

The display module contains the graphic display (256x64) dots, and backlight for the display.

3.2 TRANSCEIVER UNIT

Block diagram page 3-3, Interconnection diagram page 3-4.

The Transceiver Unit consists of five modules. Three modules located in the base part of the unit: a control and interconnection module, a receiver/exciter signal path module, and a synthesizer and DSC RX module including master oscillator, and two modules are located in the door part of the unit: a power amplifier module including filter bank and a switched mode power supply. The main wiring is by ribbon cables with Micro MaTch connectors. RF signals are routed in coaxial cables using Taico, MCX and BNC connectors.

3.3 CONTROL / INTERCON MODULE 636510

The Control/Intercon module performs the digital and analogue control of the transceiver functions requested by the control unit and contains interconnection circuits. The central part is the CPU. The program software is contained in Flash PROM. A separate Flash PROM holds the configuration parameters. The processor communicates with the CU via the CAN interface, with auxiliary equipment via an RS-232 interface and via the ATU via a modem circuit. Internal communication is via the TU Bus. The transmitter is monitored via the PA Peak, Filter Peak and Filter Average detectors. An adjustable opto-isolated battery detector circuit monitors the battery voltage at the Supply Alarm connector and triggers an alarm when outside the set range. The CPU also performs DSC modulator and dual DSC demodulator functions. The modulator output is through a transversal filter. Audio switching allows loop back test. Audio circuits convert between unbalanced and balanced lines used by the ScanBus.

3.4 SYNTH. AND DSC WR MODULE 636511

The Synthesiser part includes Master oscillator, dividers, 3.LO PLL and VCO, 2.LO filters and multiplier and 1.LO fractional N system as well as both 1. and 2. DSC LO PLL and VCO. The Master oscillator generates a 17.8176MHz reference signal which is distributed to the local LO sub-circuits. The local LO circuits then generate the appropriate frequencies used in the MF/HF transceiver and the DSC receiver.

The DSC Watch receiver includes antenna supply, Protection, front-end filters, 1.Mixer, IF amplifiers and filter, 2. Mixer, DSC filter Hard limiter and an AGC/Check circuit. The antenna supply powers an active antenna, which sends the signal through the protection circuit to the front-end filter. From the filter the signal is down converted to IF (455kHz) and passed through the first amplifier in the receiver. After some amplification the signal is sent through a SSB filter removing the frequency components far from the wanted signal, and then it is sent through the AGC amplifier. Next step is the down conversion to BB, where the major filtration is done. The filtered signal is passed through a hard limiter with an AGC output to the digital demodulator on the Control/Intercon module. The AGC output is fed to an AGC detector, which drives both the Check detector and the AGC amplifier (with some linearization)

3.5 RX/EX SIGNAL PATH MODULE 636515

The RX signal path includes protection, pre-selection, mixers, IF amplifiers, filter bank, demodulator, squelch and audio. The RX signal path has Automatic Gain Control. The RX signal path performs the handling of the received antenna signal and delivers an AF signal, via the Control/Intercon module where the AF signal is converted from an unbalanced to a balanced signal, to the Control Unit.

The RX signal path also includes a DSC receiver signal path, which uses the MF/HF signal path, until the last down conversion. DSC part includes a mixer, base band filter, hard limiter and separate AGC detector. During DSC reception, the DSC part overrules the normal MF/HF reception.

The EX signal path includes AF compressor, modulator, filter bank, mixers and EX output amplifiers. The EX signal path has Automatic Loop Control. The EX signal path generates the modulated RF signal, adjusted to correct level - ALC adjusted signal, to the Power Amplifier.

The RX / EX signal path is controlled by the Control/Intercon module and receives its injection signal from the Synth./DSC WR module.

3.6 PA AND FILTERS MODULE 636520

The PA and Filters module includes PA drivers, PA-stage, protection circuits, bias circuits key circuit and five low-pass filters with relays and relay drivers. The PA and Filters receives the modulated RF input signal from the RX/EX Signal Path and delivers the amplified and filtered output signal to the TX/RX connector via a receive/transmit relay on the Control/Intercon module.

The low-pass filters removes the unwanted harmonic frequencies from the PA signal. The Filpeak and PAprotec outputs are monitoring signals for the Control/Intercon module. The driver and final power amplifier stages are galvanic isolated on input and output as they are supplied directly from the 24 V DC input. The selection of low-pass filter is controlled by the Control/Intercon module.

The PA filters cover the frequency ranges:

- 1.6 – 3.1 MHz
- 3.1 – 5.0 MHz
- 5.0 – 9.0 MHz
- 9.0 – 17.0 MHz
- 17.0 – 29.7 MHz

3.7 SMPS MODULE 636530

The Switched Mode Power Supply supplies the low power circuits of the equipment with the various stabilized voltages required, and provides galvanic isolation from the supply source. The equipment is supplied from a 21.6 – 31.2 V DC power source. The module also carries the input filter and PA supply output which is not galvanic isolated.

The power supply converts the incoming voltage to 7.5 V, +15 V, -15, and 25 V. The SMPS is switched on from the control unit via the Scanbus SUPPLY ON wire and switched off under software control via the SUPPLY ON/OFF connection from the Control/Intercon module. The DC supply voltage is sensed by a BAT INFO detector circuit and fed to the Control/Intercon module for automatic RF output power adjustment.

3.9 TRANSCEIVER UNIT INTERCONNECTION DIAGRAM

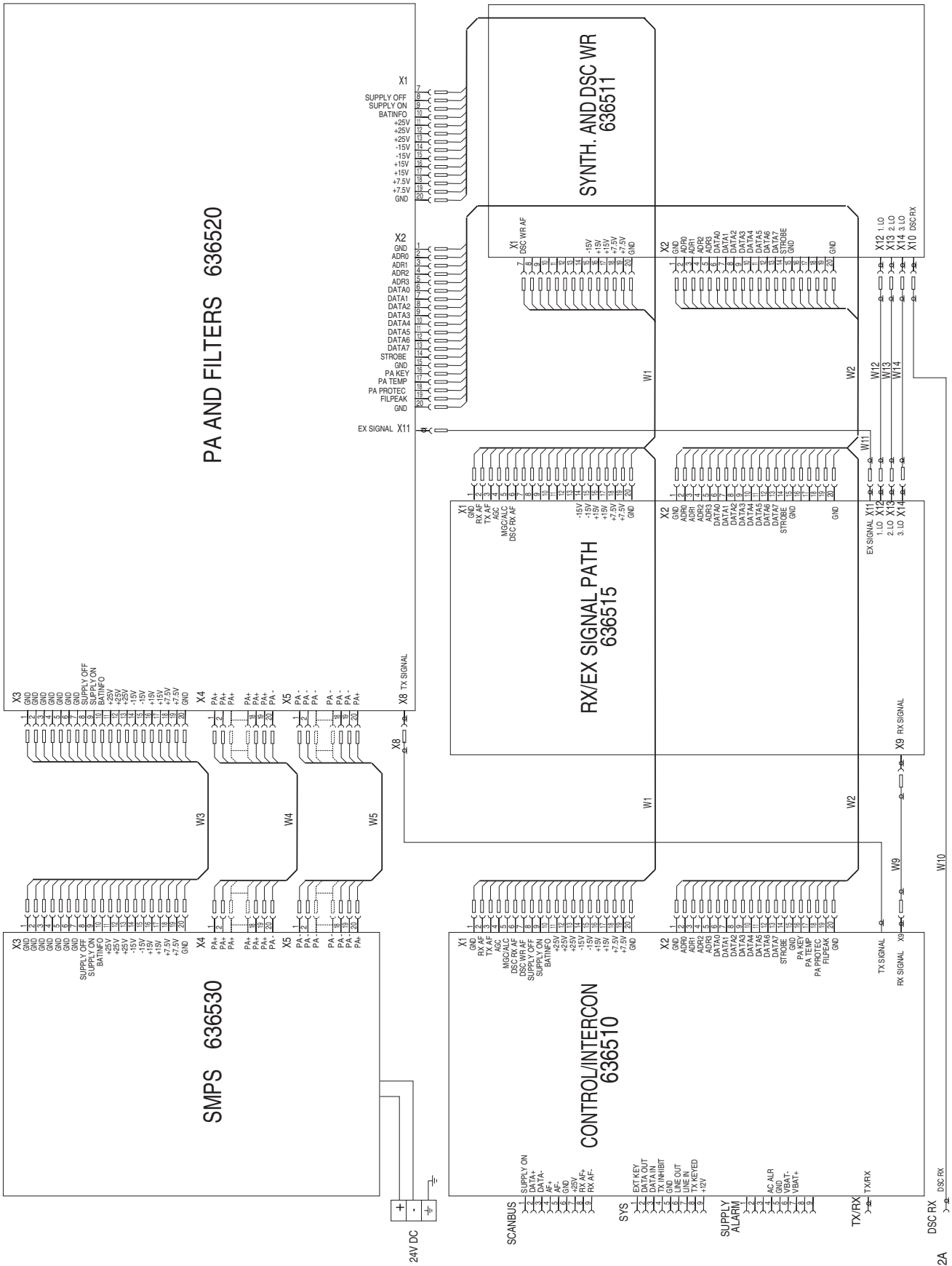

3.10 ANTENNA TUNING UNIT

ATU MODULE 636540

The ATU module comprises tuning network, measuring system and micro-controller circuits. The ATU module matches the impedance of the antenna to 50 ohm in order to gain the best possible SWR. The ATU module communicates tuning process and frequency information with the transceiver unit. The tuning network consists of Capacitor Bank 1, Capacitor Bank 2, and an Inductor Bank. With these it is possible to form either an L-network or a π -network. The capacitor banks and inductor bank are built up by binary related capacitors respectively binary related coils. The setting of capacitance and inductance is accomplished by relays. A current detector at the antenna output terminal is used for measuring the antenna current for display at the control unit. To prevent overload of the relays, current detectors are incorporated in the Inductor Bank and in Capacitor Bank 2 and information fed back to the transceiver unit to decrease the output power if maximum permissible current is exceeded. To prevent overheating a temperature sensor is incorporated which at excessive temperatures commands the transceiver to reduce the output power.

In receive mode an RX-Amplifier included in the Antenna Tuning Unit will be inserted, to improve the sensitivity of the system. It is possible to select the sensitivity in three steps (OFF, NORMAL, MAX) from the control unit.

3.11 ANTENNA TUNING UNIT BLOCK DIAGRAM

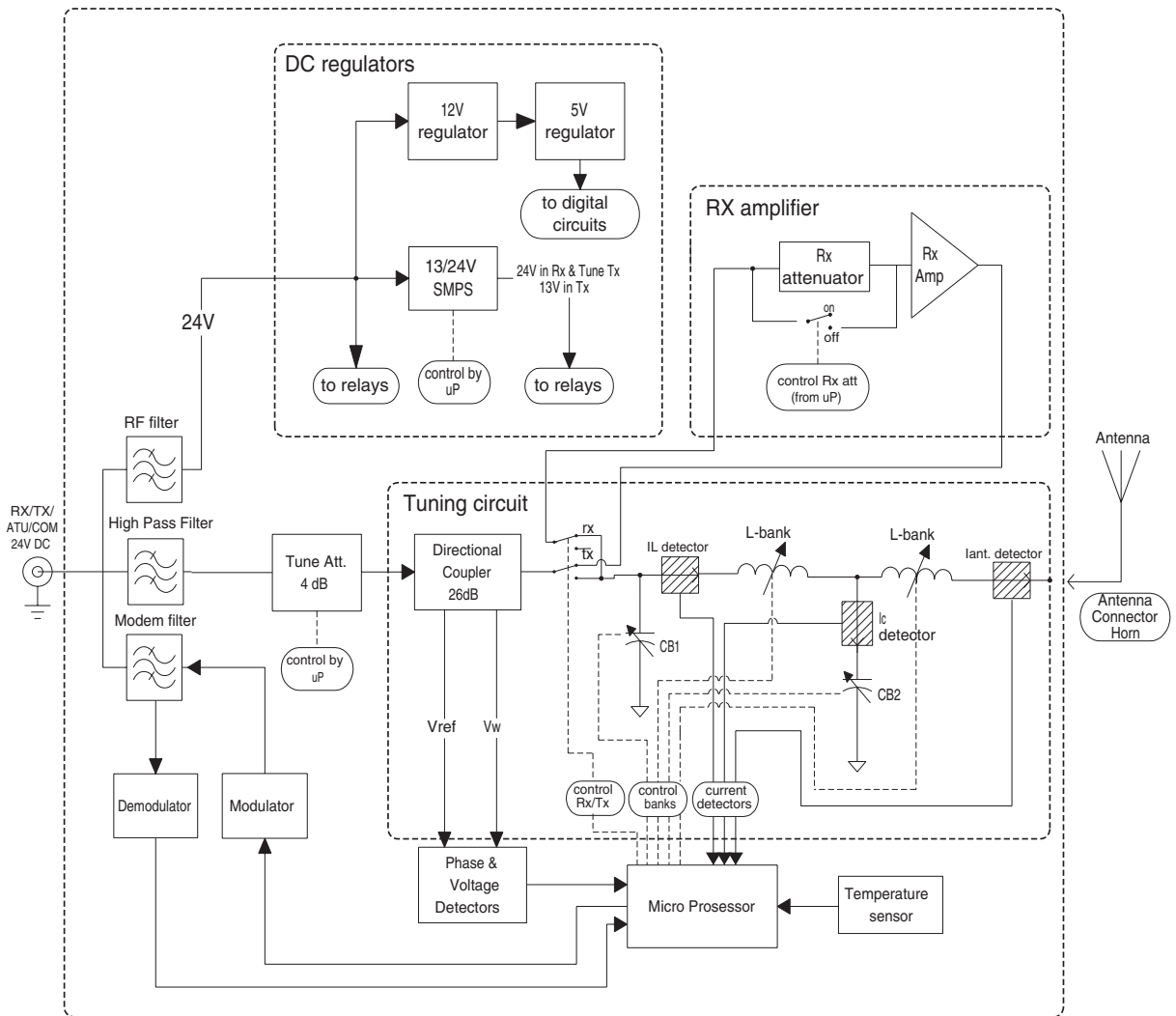

37858

3.12 POWER CONTROL AND PROTECTION SYSTEM

The Transceiver has an automatic power level system, which ensures that optimum power is delivered to the Antenna. The Tune Sequence, which is automatically initiated when keying the transmitter after a frequency change, makes the Tuning Network of the Antenna Tuning Unit tune to the best obtainable SWR. This is followed by an Automatic Level Control (ALC) adjustment according to the available power supply voltage, measuring the output current of the PA Filters (FILPEAK @ 10 Vp at full output), transmitting AM carrier, and setting the overall gain by the ALC voltage (MGC/ALC). It is now possible to transmit on full output power unless protection is activated or LOW POWER is selected. The output power is continuously monitored by the microprocessor, and is automatically adjusted during transmission to provide reliable communication .

Power Amplifier Protection

The protection of the power amplifier consists of V+I protection and thermal protection. When PA PEAK, the output signal of the voltage detector at the output of the power amplifier is exceeding 10 V the output power is reduced to a safe level. If the ALC loop is at fault, disconnected or responding too slow and the PA PEAK is exceeding 10V, the gain will be reduced in the power amplifier, operating as a local and independent PA protection. The thermal protection consist of a temperature sensor on the power amplifier and an average detector on the Control/Intercon module reducing the output power when the duty cycle of the transmitted signal exceeds 50% for more than 60 seconds. The available power supply voltage is measured in the DC power supply and the information BAT INFO is transferred to the Control/Intercon module. If the supply voltage is dropping the microprocessor will adjust the output power to keep distortion below the limits.

Antenna Tuning Unit Protection

The ATU is protected by several detectors all monitored by the ATU's microprocessor, which calculates the SWR, temperature, maximum voltage and current. If these parameters are not below safe operating limits it requests for lower power.

Protection Codes

The current status of the power control and protection may be displayed in the form of Protection Codes by selecting FUNC and the 'INFO & TEST', 'CHECK' and 'TX PROTECTION' menu items. The Protection Codes are described in the Service chapter of this manual.

It should be noted that protection may be in force even under normal conditions e.g. code nos. **25, 44** and **48**:

No. 25 requests lower Pout relatively to increasing SWR at the Power amplifier.

@ SWR= 1.1 reduction will only be a few watt's

@ SWR= 2.0 reduction will be 2-3 dB

No. 44 and 48 requests lower Pout relatively to increasing V or I at ATU.

This is normal when transmitting on lower frequencies and short antennas ($L \ll 1/4$ wavelength), and / or parallel capacitance present at the antenna, feeder, insulators, etc.

3.13 POWER CONTROL AND PROTECTION SYSTEM

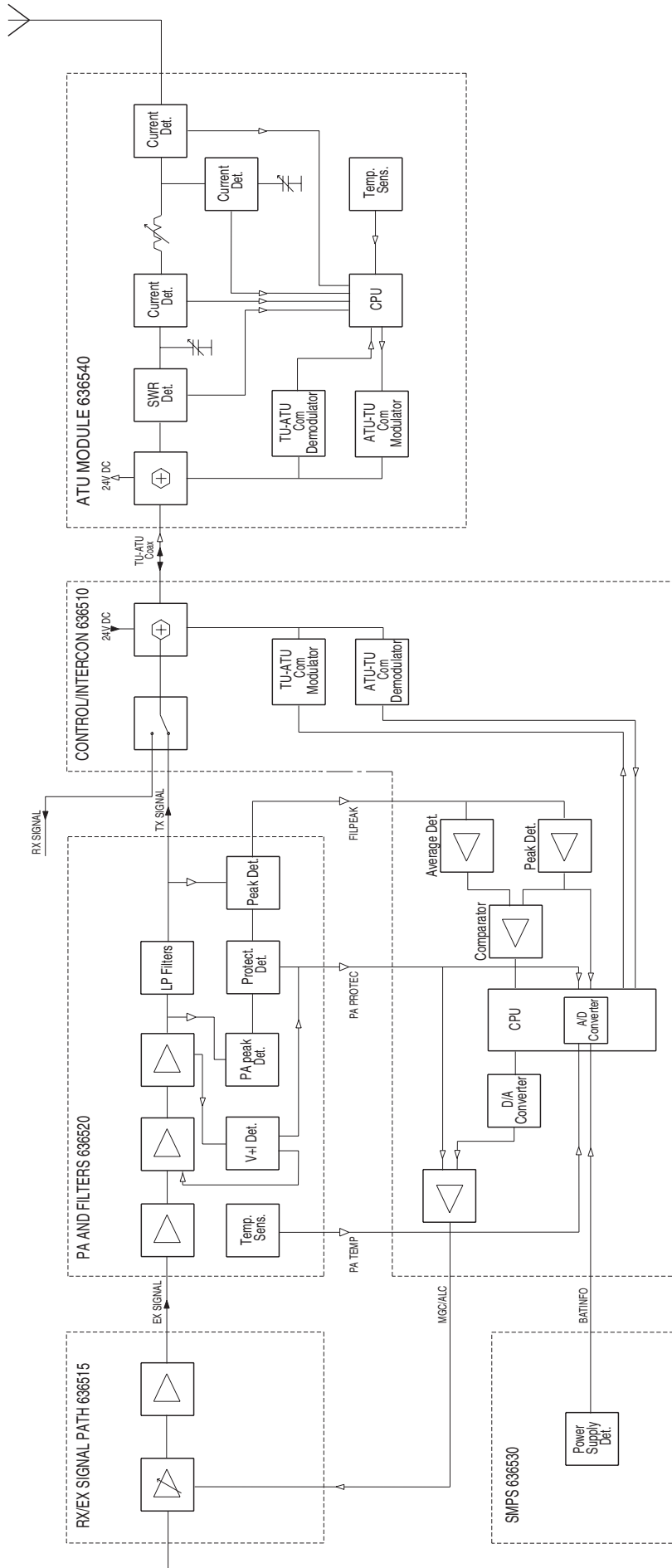

CONTENTS

4	SERVICE	4-1
4.1	PREVENTIVE MAINTENANCE	4-1
4.2	REALIGNMENT OF MASTER OSCILLATOR	4-1
4.3	SOFTWARE UPDATE	4-2
4.3.1	SETUP	4-2
4.3.2	PC	4-2
4.3.3	CABLE	4-2
4.3.4	PROCEDURE	4-2
4.4	TROUBLE SHOOTING	4-2
4.5	POWER PROTECTION	4-3
4.6	SELF TEST	4-5

4 SERVICE

4.1 PREVENTIVE MAINTENANCE

Due to the modern design of the transceiver preventive maintenance can be reduced to a minimum provided the equipment is correctly installed. To ensure maximum performance and minimum repair trouble we recommend you to follow the below stated headlines for preventive maintenance.

1. The condition of the battery should be checked at frequent intervals. The battery must always be fully charged and should be topped up frequently with distilled water (liquid should be 5 to 10 mm above the plates).
2. Check the condition of antenna installation, ground connection and cables at regular intervals.
3. Keep antenna feed-through insulators clean and dry.
4. Ensure that no objects are obstructing the free airflow through the cooling fins of the Transceiver Unit and keep the units free of dust accumulation to prevent overheating.
5. For cleaning use a damp cloth. Sticky dirt may be removed using a cloth with a weak soap solution. Wipe off with a clean cloth.

4.2 REALIGNMENT OF MASTER OSCILLATOR

The Master Oscillator determines the exact transmit and receive frequencies of the equipment. All oscillators age very slowly with time, typically with the highest drift rate the first year, approaching zero drift after some years. Adjustment should be performed by a qualified technician with the necessary test equipment at his disposal.

1. Measuring Equipment:

Frequency Counter: Frequency range 100 MHz
 Input impedance = 1 Mohm
 Sensitivity at least 0.2 Vrms
 Accuracy better than 0.01ppm

2. Preparations:

- 2.1 Switch on the power at least 30 minutes before adjustment.
- 2.2 Open the front of the Transceiver Unit.
- 2.3 Locate X13 on SYNTH.AND DSC WR module 636511 carrying the 2. Local Oscillator signal from the synthesizer to the RX/EX Signal Path. Connect the frequency counter probe to the inner conductor of the X13 socket on the synthesizer.
- 2.4 The ambient temperature should be within 10 to 30 deg. Celsius. Do not adjust the Master Oscillator shortly after long keying sequences of the transmitter. Be sure that thermal equilibrium has taken place before adjustment.

3. Realignment of Master Oscillator:

- 3.1 Locate the Master Oscillator adjustment hole in the metal cover over SYNTH.AND DSC WR module 636511. Use a small screwdriver to gently adjust the frequency.
- 3.2 Adjust the frequency as close as possible to 44.544 000 MHz.
Adjustment tolerance +/-1Hz.
- 3.3 Remove the counter probe and refit the front of the Transceiver Unit.

4.3 SOFTWARE UPDATE

Code and configuration software are placed in flash memory. Consequently it is not necessary to dismantle the units in order to update the software; a PC link must be used.

4.3.1 Setup

In order to perform a software update, a PC with a communication program (e.g. Procomm Plus or HyperTerminal) and a communication cable are required.

If the Hyper Terminal program is used it is recommended to close and re-start the program if more than one file has to be downloaded. This should be done between each file download.

4.3.2 PC

In the specific communication program, the Com port must be set to

Item	Value
Baudrate	38400
Parity	None
Data bits	8
Stop bits	1

Flow control must be set to: None

The communication protocol must be set to: X-Modem.

4.3.3 Cable

The cable must be a 3-wire cable. Supplying more than 3-wire may damage the PC. The PC side of the cable must be a 9-pin (or 25-pin) female D-sub connector; the CU/TU side must be a 9-pin male D-sub connector. The cable may be supplied as accessory.

Designation	PC 'Com port'		CABLE	CU 'Aux'	TU 'Sys'	Designation
	9-pin	25-pin		9-pin	9-pin	
Received Data	2	3		2	2	Data Out
Transmitted Data	3	2		3	3	Data In
Ground	5	7		5	5	Ground

4.3.4 Procedure

The PC with the communication program and cabling must be ready before the CU/TU is switched on. The procedure is as follows.

- Download software from the web site or receive it from your distributor if necessary.
- Switch off PC and CU/TU
- Connect cable to unit to be updated
- Switch on PC
- Enter the communication program. Setup the Com port and select X-Modem protocol. Select the upload file (the new software version) and begin uploading.
- Switch on the CU/TU.

Upload will now begin. The result of the upload will be written on the PC when the upload is finished. If the upload was successful the CU/TU reboots automatically.

4.4 TROUBLE SHOOTING

If a malfunction should occur in the transceiver, the following instructions should be followed in order to locate the module which is causing the malfunction:

1. Check the hardware configuration of the transceiver by selecting FUNC and the 'INFO & TEST', 'INFORMATION' and 'HW VERSION' menu items, in particular check that the antenna tuning unit is recognized, if installed.
2. If the malfunction is related to transmission check the current status of the power and protection monitor. A description of the 'Protection codes' is included on the following pages.

3. If possible execute the built in self test. An 'Error code' for the failing module will be displayed. A description of the 'Error codes' is included in the Self Test section of this chapter.
4. If an execution of the self test failed, check that all cables and plugs are correctly connected, and that the supply voltage is correct. At this point the fuses should be checked.
5. The next step is to open the Transceiver Unit and :
 - a. Check the internal fuse, cables and plugs.
 - b. Check that the +5 V LED (Light Emitting Diode) V1 on the PA AND FILTERS module 636520 is constantly on; indicating that the Switch Mode Power Supply is on and able to produce +7.5 V DC.
6. If the above steps did not help, please contact your local service agent.
A list of service agents is found on the Internet.

4.5 POWER PROTECTION

The Power and Protection system is monitoring the transmitter circuits during transmission and will automatically maximize the radiated power to safe limits. The current status of the Power and Protection monitor is presented in form of protection codes and may be requested at any time by selecting FUNC and the 'INFO &TEST', 'CHECK', 'TX PROTECTION' menu items.

The display will show the Protection Code. More than one Protection Code may be set. Protection is automatically reset when the transmit conditions are normalized.

Protection Code Groups:

No.	Group
00	No protection set
10 - 17	TU power regulation problems. Perform a Self Test.
20 - 23	TU hardware protection.
40 - 51	ATU protection.

Protection Code explanation:

0	No protection
10	Tune Power Low
Measurement:	CONTROL/INTERCON module 636510 measures too low power output. Tune power < 20W.
Protection made:	ATU selects feed through setting after „TU Failure“ command. Power regulation inhibited
Possible cause:	TU - ATU coaxial cable open.
11	Tune Power High
Measurement:	CONTROL/INTERCON module 636510 measures too high power output. Tune power > 30W.
Protection made:	ATU selects feed through setting after „TU Failure“ command.
12	ALC Power High
Measurement:	CONTROL/INTERCON module 636510 measures too high power output. ALC power was too high.
Protection made:	Exciter level set to approx. +8dBm.
13	Supply failure
Measurement:	Supply voltage higher than 33 V
Protection made:	TX key inhibited. Note: It is necessary to press TUNE to reset the protection.

14	ALC Power Low
Measurement:	CONTROL/INTERCON module 636510 measures too low power output. ALC power was too low.
Protection made:	Exciter level set to approx. +8dBm.
15	TU-ATU Failure
Measurement:	CONTROL/INTERCON module 636510 measures too high power output. ATU requests lower output power and TU has reached minimum.
Protection made:	Automatic power regulation inhibited.
16	Low Power High
Measurement:	CONTROL/INTERCON module 636510 measures too high power output. Low Power was too high.
Protection made:	Power set as Low as possible.
17	Full Power High
Measurement:	CONTROL/INTERCON module 636510 measures too high power output. Full Power was too high.
Protection made:	Automatic power regulation inhibited.
20	PA Temp
Measurement:	PA temperature too high.
Protection made:	Output power decreased.
Possible cause:	Free airflow through the cooling fins of the Transceiver Unit impaired.
21	PA SWR high
Measurement:	PA SWR was too high. Reflected power was detected.
Protection made:	Output power decreased.
Possible cause:	TU - ATU coaxial cable or antenna.
22	High Average
Measurement:	Average power reduced to 100W.
Possible cause:	CW keyed for more than 1 minute.
23	PA Hot
Measurement:	PA temperature continuously high.
Protection made:	Key inhibit for 5 min.
Possible cause:	Free airflow through the cooling fins of the Transceiver Unit impaired.
25	PA SWR
Measurement:	PA SWR was high.
Protection made:	Output power reduced to safe limits.
Possible cause:	High SWR or change in antenna impedance.
40	Not Tuned
Measurement:	ATU failed tuning the antenna.
Protection made:	ATU selects feed through setting.
Possible cause:	Antenna installation.
41	No Tune Power
Measurement:	ATU measured no tune power.
Protection made:	ATU selects feed through setting.
Possible cause:	TU - ATU coaxial cable shorted.
42	Bad SWR
Measurement:	ATU measured SWR > 8 during Tune Procedure.
Protection made:	ATU selects feed through setting.
Possible cause:	Bad antenna impedance on the selected frequency.

43	High SWR
Measurement:	ATU measured SWR >3 but <8 during Tune Procedure.
Possible cause:	Poor antenna impedance on the selected frequency.
44	V or I
Measurement:	ATU measured that the maximum voltage or current rating is reached during ALC adjustment.
Possible cause:	A short antenna and a low frequency.
45	Temp
Measurement:	ATU requests for lower power during TX.
Possible cause:	Temperature inside ATU cabinet is too high.
46	Bad SWR TX
Measurement:	ATU measured SWR > 8 during transmission.
Possible cause:	Bad antenna impedance on the selected frequency.
47	High SWR TX
Measurement:	ATU measured SWR >3 but <8 during transmission.
Possible cause:	Poor antenna impedance on the selected frequency.
48	V or I high TX
Measurement:	ATU measured that the maximum voltage or current rating is reached during transmission.
Possible cause:	A short antenna and a low frequency.
50	V or I high
Measurement:	ATU measured that the maximum voltage or current rating is reached during ALC adjustment and the power had to be reduced more than 6 dB.
Possible cause:	A bad antenna and a low frequency.
51	TU-ATU com bad
Measurement:	TU - ATU communication is not operating.
Protection made:	Key inhibit.
Possible cause:	TU - ATU communication problem.

4.6 SELF TEST

Introduction

The 'SELF TEST' BITE (Built-In Test Equipment) of the transceiver is used as a fault diagnosing tool for the service technician. It may also be used by the operator to obtain additional information on a problem when ordering service.

The 'SELF TEST' checks the vital functions of the Transceivers modules by performing and monitoring a sequence of operations. The program controls the analog and digital set ups necessary to perform each test step in the line of tests executed during the 'SELF TEST'. These set ups will result in a digital feed back from go/no-go analog check detectors, A/D converters or digital circuits.

Self test description

The 'SELF TEST' is started by selecting FUNC and the 'INFO &TEST', 'CHECK', 'SELFTEST' menu items. All tests which does not involve transmission will automatically be performed successively until the last test has passed or an error condition has occurred. The test number and a name is displayed as the test proceeds.

After the last test the user has the option to continue with a test of the transmitter with power delivered to the antenna. The user selects the test frequency. Both receiver and transmitter are set to the test frequency which should be selected so as to cause minimal disturbance of others.

If stopped due to an error condition, an error code is displayed. Only one error code is given as a result of each test (the lowest number fitting). The user has the option to repeat the test or cancel.

It is also possible to select a single test step for service purposes. Tests may be repeated several times giving a technician the opportunity to make measurements. Note that test on an arbitrary test number may provide a false indication to where the problem is, as the self test assumes that all previous test steps have been performed and found OK.

Explanations to the 'Error codes' are listed on the following pages.

Test 1 - CU RAM

A write/read test is performed on the Random Access Memory in the Control Unit.

Error code	Conditions	Possible error sources
0101	CU RAM failure	CONTROL UNIT

Test 2 - CU CAN Controller

A test is performed on the CAN connection between CU and TU.

Error code	Conditions	Possible error sources
0201	No CAN connection	ScanBus cable or CONTROL UNIT or CONTROL/INTERCON 636510
0202	CAN connection lost	ScanBus cable or CONTROL UNIT or CONTROL/INTERCON 636510

Test 3 - TU RAM

A write/read test is performed on the Random Access Memory in the Transceiver Unit.

Error code	Conditions	Possible error sources
0301	TU RAM failure	CONTROL/INTERCON module 636510

Test 4 - SUPPLY VOLTAGES

+15 V and -15 V is checked. *(This test is not implemented initially).*

Error code	Conditions	Possible error sources
0401	+15 V missing	SMPS 636530 or cabling
0402	-15 V missing	SMPS 636530 or cabling

Test 5 - DSC MODEM

A loop-back test is made on the DSC modulator/demodulators.

Error code	Conditions	Possible error sources
0501	Demodulator 1 failure	CONTROL/INTERCON module 636510
0502	Demodulator 2 failure	CONTROL/INTERCON module 636510
0503	Modulator or demodulator 1 and demodulator 2 failure	CONTROL/INTERCON module 636510

Test 6 - MMSI

The CU checks that the MMSI has been programmed and that transfer to the modem has been successful.

Error code	Conditions	Possible error sources
0601	MMSI not programmed	Programming left out
0602	MMSI not transferred to TU	ScanBus cable or CONTROL UNIT or CONTROL/INTERCON 636510"

Test 7 - MASTER OSCILLATOR

The Master oscillator output is checked for signal.

Error code	Conditions	Possible error sources
0701	MO CHECK = No signal	SYNTH. AND DSC WR module 636511 or SMPS module 636530 or cabling

Test 8 - 2. LO

2. LO is checked for signal.

Error code	Conditions	Possible error sources
0801	2. LO CHECK = No signal	SYNTH. AND DSC WR module 636511

Test 9 - 1. LO out of lock

Tests if 1. LO gets out of lock by setting it to an out-of-band frequency to check that the microprocessor can control the synthesizer.

Settings:

Band: 45 – 52.5 MHz

1. LO: 75.00000 MHz

Error code	Conditions	Possible error sources
0901	1. LO CHECK = Lock	SYNTH. AND DSC WR module 636511

Test 10 - 1. LO band 0 low border

1. LO is checked for lock in band 0, low border.

Settings:

Band: 45 – 52.5 MHz

1. LO: 45.00000 MHz

Error code	Conditions	Possible error sources
1001	1. LO CHECK = No lock	SYNTH. AND DSC WR module 636511

Test 11 - 1. LO band 0 high border

1. LO is checked for lock in band 0, high border.

Settings:

Band: 45 – 52.5 MHz

1. LO: 52.50000 MHz

Error code	Conditions	Possible error sources
1101	1. LO CHECK = No lock	SYNTH. AND DSC WR module 636511

Test 12 - 1. LO band 1 low border

1. LO is checked for lock in band 1, low border.

Settings:

Band: 52.5 - 60 MHz

1. LO: 52.50000 MHz

Error code	Conditions	Possible error sources
1201	1. LO CHECK = No lock	SYNTH. AND DSC WR module 636511

Test 13 - 1. LO band 1 high border

1. LO is checked for lock in band 1, high border.

Settings:

Band: 52.5 - 60 MHz

1. LO: 60.00000 MHz

Error code	Conditions	Possible error sources
1301	1. LO CHECK = No lock	SYNTH. AND DSC WR module 636511

Test 14 - 1. LO band 2 low border

1. LO is checked for lock in band 2, low border.

Settings:

Band: 60 – 67.5 MHz

1. LO: 60.00000 MHz

Error code	Conditions	Possible error sources
1401	1. LO CHECK = No lock	SYNTH. AND DSC WR module 636511

Test 15 - 1. LO band 2 high border

1. LO is checked for lock in band 2, high border.

Settings:

Band: 60 – 67.5 MHz

1. LO: 67.50000 MHz

Error code	Conditions	Possible error sources
1501	1. LO CHECK = No lock	SYNTH. AND DSC WR module 636511

Test 16 - 1. LO band 3 low border

1. LO is checked for lock in band 3, low border.

Settings:

Band: 67.5 – 75 MHz

1. LO: 67.50000 MHz

Error code	Conditions	Possible error sources
1601	1. LO CHECK = No lock	SYNTH. AND DSC WR module 636511

Test 17 - 1. LO band 3 high border

1. LO is checked for lock in band 3, high border.

Settings:

Band: 67.5 – 75 MHz

1. LO: 75.00000 MHz

Error code	Conditions	Possible error sources
1701	1. LO CHECK = No lock	SYNTH. AND DSC WR module 636511

Test 18 - 3. LO out of lock

Tests if 3. LO gets out of lock by setting it to an out-of-band frequency to check that the microprocessor can control the synthesizer.

Settings:

3. LO: 400.00 kHz

Error code	Conditions	Possible error sources
1801	3. LO CHECK = Lock	SYNTH. AND DSC WR module 636511

Test 19 - 3. LO low border

3. LO is checked for lock at low border.

Settings:

3. LO: 452.50 kHz

Error code	Conditions	Possible error sources
1901	3. LO CHECK = No lock	SYNTH. AND DSC WR module 636511

Test 20 - 3. LO high border

3. LO is checked for lock at high border.

Settings:

3. LO: 460.50 kHz

Error code	Conditions	Possible error sources
2001	3. LO CHECK = No lock	SYNTH. AND DSC WR module 636511

Test 21 - 1. LO DSC out of lock

Tests if 1. LO of the DSC watch receiver gets out of lock by setting it to an out-of-band frequency to check that the microprocessor can control the synthesizer.

Error code	Conditions	Possible error sources
2101	DSC 1. LO CHECK = Lock	SYNTH. AND DSC WR module 636511

Test 22 - 1. LO DSC

1. LO of the DSC Watch Receiver is checked for lock at the nominal frequency.

Settings:

1. LO DSC: 2.6425 MHz

Error code	Conditions	Possible error sources
2201	DSC 1. LO CHECK = No lock	SYNTH. AND DSC WR module 636511

Test 23 - 2. LO DSC out of lock

Tests if 2. LO of the DSC Watch Receiver gets out of lock by setting it to an out-of-band frequency to check that the microprocessor can control the synthesizer.

Error code	Conditions	Possible error sources
2301	DSC 2. LO CHECK = Lock	SYNTH. AND DSC WR module 636511

Test 24 - 2. LO DSC

2. LO of the DSC Watch Receiver is checked for lock at the nominal frequency.

Settings:

2. LO DSC: 456.7 kHz

Error code	Conditions	Possible error sources
2401	DSC 2. LO CHECK = No lock	SYNTH. AND DSC WR module 636511

Test 25 - DSC WR

The DSC Watch Receiver signal path is checked by injecting a 2227.2 kHz test signal at the receiver input. The output is checked for signal by measuring the AGC voltage.

Settings:

1. LO DSC: 2.6822 MHz

2. LO DSC: 456.70 kHz

CHECK GEN ENB = On

Error code	Conditions	Possible error sources
2501	DSC WR CHECK = No signal	SYNTH. AND DSC WR module 636511

Test 26 - DSC WR with no signal

The DSC Watch Receiver signal path is checked with no signal. The 2. LO DSC is offset by 5 kHz to mute antenna signals. The output is checked for no signal by measuring the AGC voltage.

Settings:

1. LO DSC: 2.6822 MHz

2. LO DSC: 461.70 kHz

CHECK GEN ENB = Off

Error code	Conditions	Possible error sources
2601	DSC WR CHECK = Signal	SYNTH. AND DSC WR module 636511

[Test 27 - reserved]

Test 28 - RX AF path on CONTROL/INTERCON module 636510 with no signal

The AF path on Control and Interconnection 636510 is checked with no signal present.

Error code	Conditions	Possible error sources
2801	RX AF CHECK 510 = Signal	CONTROL/INTERCON module 636510

Test 29 - RX AF path on CONTROL/INTERCON module 636510 with signal

The AF path on Control and Interconnection 510 with signal present.

A 2227.2 kHz test signal is injected at the DSC WR receiver input and DSC RX AF is routed to the output and the RX AF is checked for signal.

Settings:

1. LO DSC: 2.6822 MHz

2. LO DSC: 456.70 kHz

Error code	Conditions	Possible error sources
2901	RX AF CHECK 510 = No signal	CONTROL/INTERCON module 636510 or
	SYNTH. AND DSC WR module 636511 or cabling	

Test 30 - RX AF path on RX/EX SIGNAL PATH module 636515 with no signal.

Tests the RX AF path on RX/EX Signal Path 636515 with no signal present.

Error code	Conditions	Possible error sources
3001	RX AF CHECK 515 = Signal	RX/EX SIGNAL PATH module 636515
3002	RX AF CHECK 510 = Signal	CONTROL/INTERCON module 636510 or RX/EX SIGNAL PATH module 636515

Test 31 - RX SSB mode

The receiver of the RX/EX Signal Path 636515 is checked in SSB mode. By choosing the proper synthesizer frequencies the signal passes the 45 MHz filter and is mixed to a 1 kHz tone in the audio part. The automatic gain control voltage and RX AF is checked.

Settings:

Band: 45 – 52.5 MHz

1. LO: 44.99900 MHz

3. LO: 456.00 kHz

Error code	Conditions	Possible error sources
3101	RX AF CHECK 515 = No signal	RX/EX SIGNAL PATH module 636515
3102	RX AF CHECK 510 = No signal	CONTROL/INTERCON module 636510
3103	No AGC voltage	RX/EX SIGNAL PATH module 636515 or CONTROL/INTERCON module 636510 or cabling

Test 32 - RX AM mode

The receiver of the RX/EX Signal Path 636515 is checked in AM mode. By choosing the proper synthesizer frequency the signal passes the 45 MHz filter and is mixed to generate an unmodulated carrier. The automatic gain control voltage and RX AF is checked.

Settings:

Band: 45 – 52.5 MHz

1. LO: 44.99900 MHz

Error code	Conditions	Possible error sources
3201	RX AF CHECK 515 = Signal	RX/EX SIGNAL PATH module 636515
3202	No AGC voltage	RX/EX SIGNAL PATH module 636515 or CONTROL/INTERCON module 636510

Test 33 - RX DSC mode

The receiver of the RX/EX Signal Path 636515 is checked in DSC mode. By choosing the proper synthesizer frequencies the signal passes the 45 MHz filter and is mixed to a 1.7 kHz tone in the audio part. RX AF is checked.

Settings:

Band: 45 – 52.5 MHz

1. LO: 44.99900 MHz

3. LO: 456.70 kHz

Error code	Conditions	Possible error sources
3301	DSC AF CHECK = No signal	RX/EX SIGNAL PATH module 636515
3302	RX AF CHECK 515 = No signal	RX/EX SIGNAL PATH module 636515
3303	RX AF CHECK 510 = No signal	CONTROL/INTERCON module 636510

Test 34 - SQUELCH

The squelch circuit of the RX/EX Signal Path 636515 is checked in SSB mode. By choosing the proper synthesizer frequencies the signal passes the 45 MHz filter and is mixed to a 500 Hz tone in the audio part. This makes the squelch open. Then a 2 kHz tone is generated making the squelch close. Squelch hold time is also checked.

Settings:

Band: 45 – 52.5 MHz

1. LO: 44.99900 MHz

a) 3. LO: 455.50 kHz (500Hz tone)

b) 3. LO: 457.00 kHz (2 kHz tone)

Error code	Conditions	Possible error sources
3401	RX AF CHECK 515 = No signal with 500 Hz tone.	RX/EX SIGNAL PATH module 636515
3402	RX AF CHECK 515 = Signal with 2 kHz tone.	RX/EX SIGNAL PATH module 636515
3403	Squelch hold time not ok.	RX/EX SIGNAL PATH module 636515

Test 35 - RX AGC

The gain control circuit of the RX/EX Signal Path 636515 is checked. By choosing the proper synthesizer frequency the signal passes the 45 MHz filter and is mixed to a 1 kHz tone in the audio part. By setting the MGC voltage to low sensitivity the RX AF Check should indicate no AF signal. By setting the MGC voltage to high sensitivity the RX AF Check should indicate AF signal present.

Settings:

Band: 45 – 52.5 MHz

1. LO: 44.99900 MHz

3. LO: 456.00 kHz

Error code	Conditions	Possible error sources
3501	RX AF CHECK 515 = Signal with MGC voltage at max.	RX/EX SIGNAL PATH module 636515 or CONTROL/INTERCON module 636510
3502	RX AF CHECK 515 = No signal with MGC voltage at min.	RX/EX SIGNAL PATH module 636515 or CONTROL/INTERCON module 636510

Test 36 - RX ACG hang time

The Automatic Gain Control Hang facility of the RX/EX Signal Path 636515 is checked. By choosing the proper synthesizer frequency the signal passes the 45 MHz filter and is mixed to a 1 kHz tone in the audio part. The hang function is examined in three steps:

- 1) Check normal AGC with 1 kHz tone
- 2) Check that AGC hangs with no signal
- 3) Check that AGC hang time has ended.

Settings:

Band: 45 – 52.5 MHz

1. LO: 44.99900 MHz

3. LO: 456.00 kHz

Band: 67.5 – 75 MHz

1. LO: 80.00000 MHz

3. LO: 456.00 kHz

Error code	Conditions	Possible error sources
3601	No AGC voltage with signal on	RX/EX SIGNAL PATH module 636515 or CONTROL/INTERCON module 636510
3602	Hang time too short	RX/EX SIGNAL PATH module 636515 or CONTROL/INTERCON module 636510
3603	Hang time too long	RX/EX SIGNAL PATH module 636515 or CONTROL/INTERCON module 636510

Test 37 - EX SSB with no signal.

The exciter of the RX/EX Signal Path 636515 is checked in SSB mode. PA and Filters 636520 is not keyed. The exciter is set to produce a 15 MHz SSB signal. No AF input signal. No RF should be detected at the exciter output.

Settings:

Band: 60 – 67.5 MHz

1. LO: 60.00000 MHz

3. LO: 456.50 kHz

Error code	Conditions	Possible error sources
3701	EX CHECK = Signal	RX/EX SIGNAL PATH module 636515
3702	TX AF CHECK = Signal	RX/EX SIGNAL PATH module 636515 or CONTROL/INTERCON module 636510

Test 38 - EX SSB with signal.

The exciter of the RX/EX Signal Path 636515 is checked in SSB mode. PA and Filters 636520 is not keyed. The exciter is set to produce a 15 MHz SSB signal. Input tone from DSC modulator on Control and Interface Module 510. RF should be detected at the exciter output.

Settings:

Band: 60 – 67.5 MHz

1. LO: 60.00000 MHz

3. LO: 456.50 kHz

Error code	Conditions	Possible error sources
3801	EX CHECK = No signal and TX AF CHECK = Signal	RX/EX SIGNAL PATH module 636515
3802	EX CHECK = No signal and TX AF CHECK = No signal	RX/EX SIGNAL PATH module 636515 or CONTROL/INTERCON module 636510 or W1

[Test 39 - reserved]

[Test 40 - reserved]

Test 41 - EX TUNE CW

The exciter of the RX/EX Signal Path 636515 is checked in Tune CW mode. PA and Filters 636520 is not keyed. The exciter is set to produce a 15 MHz carrier. No AF input signal. RF should be detected at the exciter output.

Settings:

Band: 60 – 67.5 MHz

1. LO: 60.00000 MHz

3. LO: 456.50 kHz

Error code	Conditions	Possible error sources
4101	EX CHECK = No signal	RX/EX SIGNAL PATH module 636515

Test 42 - EX ALC

The Automatic Level Control on the RX/EX Signal Path 636515 is checked. PA and Filters 636520 is not keyed. The exciter is set to produce a 15 MHz CW carrier. No AF input signal. Low and high ALC level. No RF should be detected at the exciter output with low ALC level. RF should be detected with high ALC level.

Settings:

Band: 60 – 67.5 MHz

1. LO: 60.00000 MHz

3. LO: 456.50 kHz

Error code	Conditions	Possible error sources
4201	EX CHECK = Signal with ALC low	RX/EX SIGNAL PATH module 636515 or CONTROL/INTERCON module 636510
4202	EX CHECK = No signal with ALC high	RX/EX SIGNAL PATH module 636515 or CONTROL/INTERCON module 636510

Test 43 - ATU without RF power

The ATU Module 636540 is checked without transmitting. The Transceiver Unit checks that an ATU is connected and is able to communicate with the TU. The ATU tests RAM, Vforward-, Vreflected-, 0 degrees-, 90 degrees-, and temperature- detectors.

Error code	Conditions	Possible error sources
4301	'ATU not installed' selected in FUNC menu.	Select CONTINUE to bypass test
4302	Communication failure	ATU or CONTROL/INTERCON module 636510 or coax cable
4303	ATU RAM error	ATU
4304	Vforward detector	ATU
4305	Vreflected detector	ATU
4306	0 degrees detector	ATU
4307	90 degrees detector	ATU
4308	Temperature sensor	ATU

[Test 44 - reserved]

[Test 45 - reserved]

Test 46 - TX

The user may enter a test frequency and listen for signals to ensure that the frequency is free, before the transmitter tests are carried out.

PA and Filters 636520 and ATU Module 636540 is checked. A full tune and ALC procedure is performed on a frequency chosen by the user. Then a transmission with full power is carried out for 10 seconds, followed by a transmission in low power mode also lasting 10 seconds.

Error code	Conditions	Possible error sources
4610	Tune power low	W1 or W2 or W8 or W11
4611	Tune power high	W1 or W2
4612	ALC power high	W1 or W2
4613	Supply failure	W1
4614	ALC power low	W1 or W2
4615	TU – ATU failure	Coax cable TU – ATU or Antenna installation or W15 or ATU
4616	Low power high	W1 or W2
4617	Full power high	W1 or W2
4620	PA temperature high	PA AND FILTERS module
4621	PA SWR high	Antenna installation or PA AND FILTERS module
4640	Not tuned	Antenna installation or ATU
4641	No tune power	CONTROL/INTERCON module 636510 or W15 or Coax cable TU – ATU shorted or ATU
4642	Bad SWR	Antenna installation or ATU
4646	Bad SWR TX	Antenna installation or ATU

CONTENTS

5	SPARE PART EXCHANGE	5-1
5.1	DISASSEMBLING THE TRANSCEIVER UNIT	5-1
5.2	TRANSCEIVER UNIT MODULE LOCATION	5-1
5.3	SPARE PARTS LIST	5-4
5.4	REQUIRED SERVICE TOOL	5-4
5.5	ACCESSORY LIST	5-5

5 SPARE PART EXCHANGE

5.1 DISASSEMBLING THE TRANSCEIVER UNIT

To open the transceiver unit loosen the 4 torx screws (2 on each side) on the side of the cabinet. Move the screws to the side to unlock the TU. Now open the TU by pulling the front door towards you.

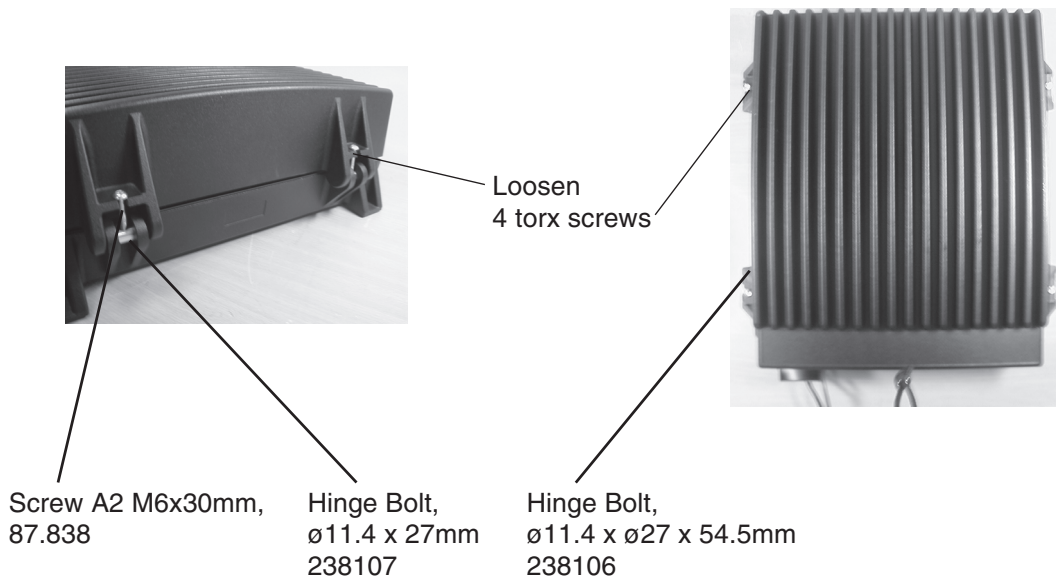

5.2 TRANSCEIVER UNIT MODULE LOCATION

The following modules are available as service parts.

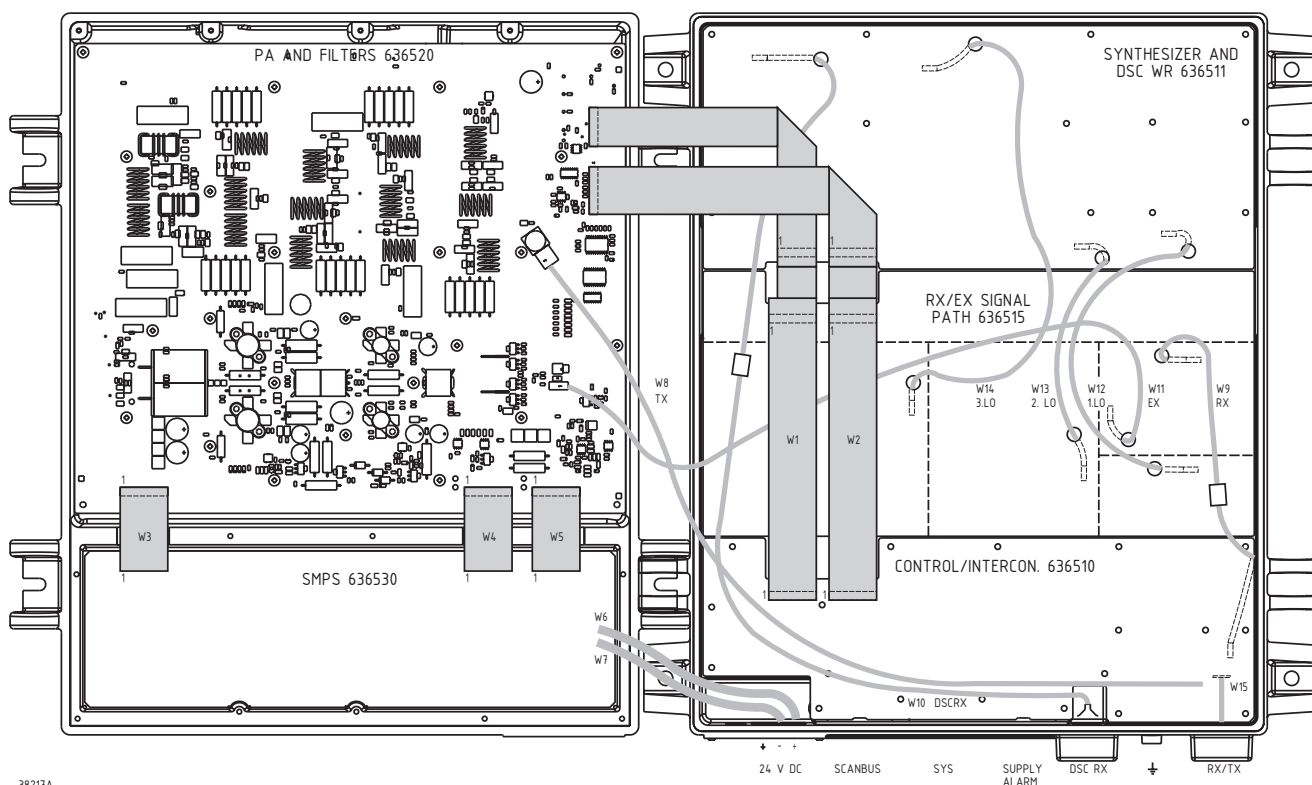

38217A

PA and Filters with SMPS Module

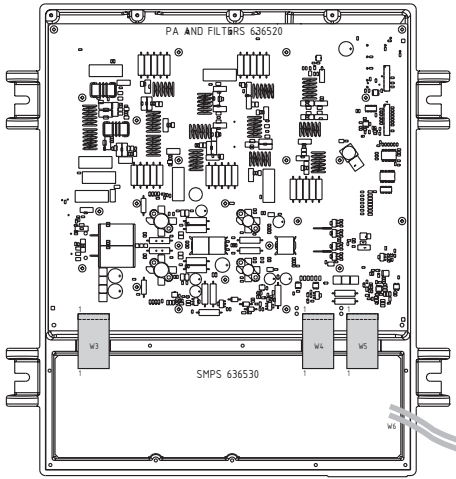

38304

Control / Intercon. Module 636510

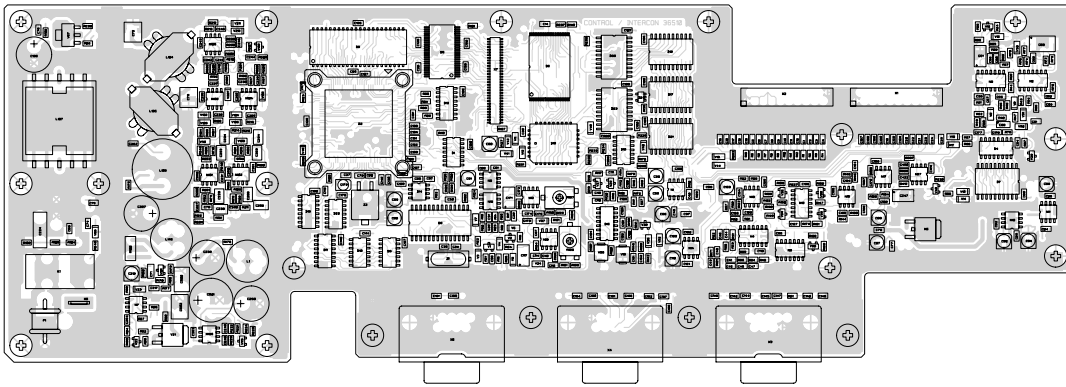

Synthesizer and DSC WR Module 636511

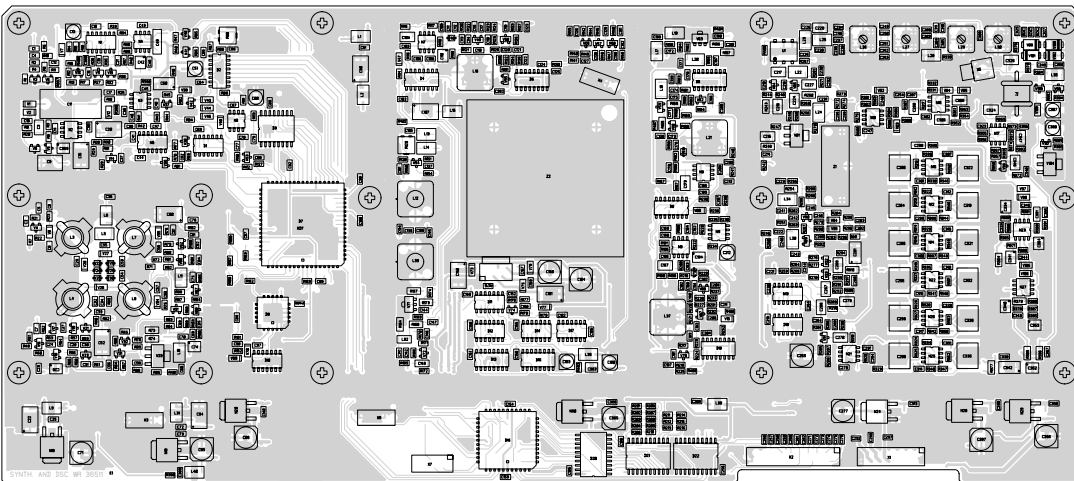

RX/EX Signal Path Module 636515

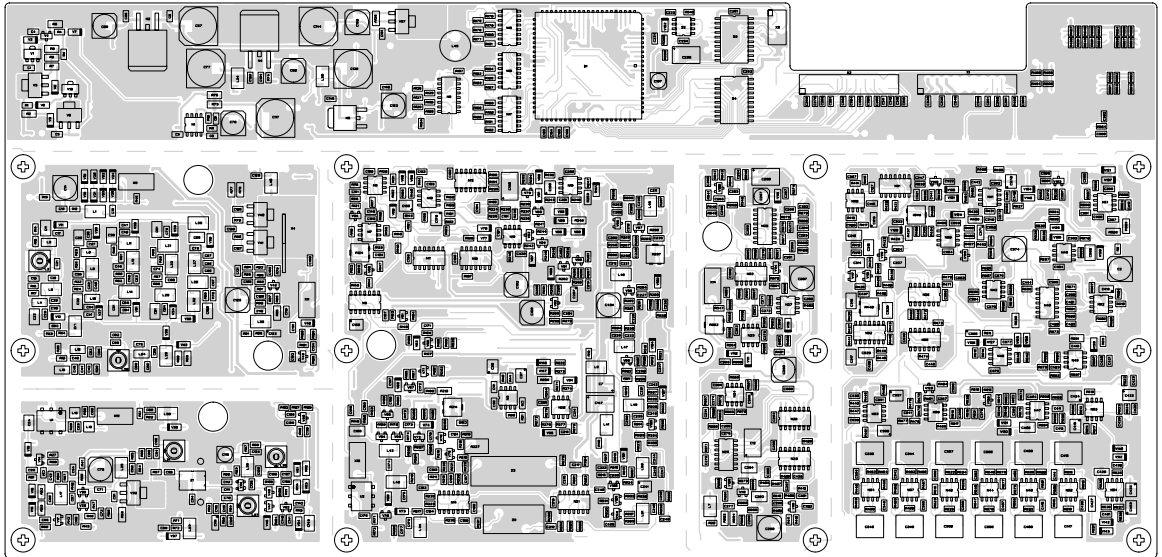

SMPS Module 636530

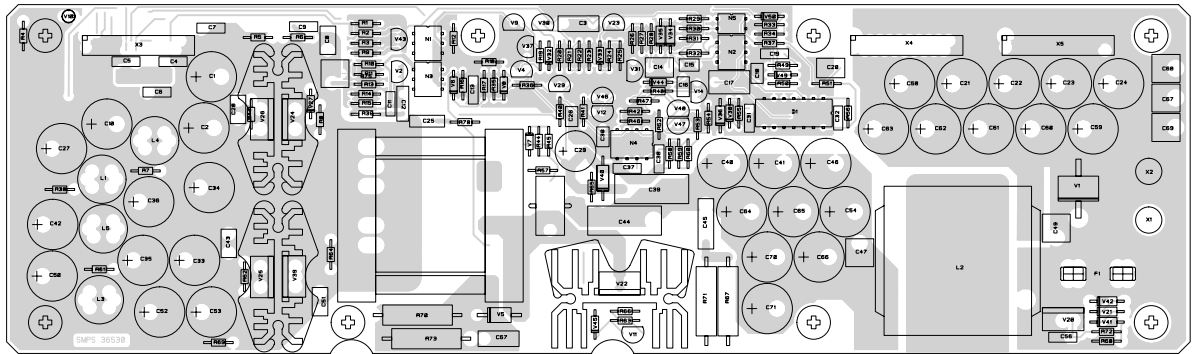

5.3 SPARE PARTS LIST

NAME	PART NO.
MF/HF Control Unit (CU)	824500xx/824501xx(*)
MH/HF Control Unit (CU) Class E	804601xxxx(*)
Antenna Tuning Unit (ATU)	804615xx(*)
Antenna Tuning Unit (ATU) Class E	8046190003
PA and Filters with SMPS Module	73809x (*)
Synthesizer and DSC WR Module	636511
RX/EX Signal Path Module	636515
SMPS Module	636530
Control / Intercon. Module	636510
W1 Ribbon Cable 2x10 Poles, 4xu.Match Male, L=500mm	538155
W2 Ribbon Cable 2x10 Poles, 4xu.Match Male, L=500mm	537748
W3-W5 Ribbon cable, 2 x 20 pole u-Match, L=100mm	537201
W6 Cable 6mm ² 180mm, Red	537676
W7 Cable 6mm ² 170mm, Black	737677
W8 Coax Cable RG58 BNC Male, L= 510mm	537753
W9 Coax Cable 2xTaico Denki male, ø3x280mm	537749
W10 Coax Cable RG316 MCX Male/SO239, L= 645mm	537752
W11 Coax Cable 2xTaico Denki male, ø3x465mm	537829
W12 Coax Cable 2xTaico Denki male, ø3x210mm	537751
W13 Coax Cable 2xTaico Denki male, ø3x210mm	537751
W14 Coax Cable 2xTaico Denki male, ø3x385mm	537750
W15 Cable 0.75mm ² 4.8mm spade/SO239, L=75mm	537754
Hinge Bolt, ø11.4 x 27mm	238107
Hinge Bolt, ø11.4 x ø27 x 54.5mm	238106
Hexagon Socket Button Head Screw A2 M6x30mm, black	87.838
Cable Fittings 70 x 80mm	238118
ATU Mounting Kit:	
Mounting plate and fittings for mast.	737589
Mounting plate	737588

* (Please find specific order numbers in Operator's Manual, page vii)

5.4 REQUIRED SERVICE TOOL

For disassembling Transceiver Unit	TORX 25 (X25)
For shield cover, print and cables	TORX 10 (X10).

5.5 ACCESSORY LIST

NAME	PART NO.
AC Power Supply	804655xx(*)
AC Power Supply Class E	8046650006
Battery Charger	804656xx(*)
Battery Charger Class E	8046660006
LS4970 External 5W speaker	80497010
CB4616 SUBD-9 to Terminal Block Converter	804616 (*)
CB4618 Handset Connection Box	804618 (*)
3-wire Data download Cable	532506
ATU Mounting Kit:	
Mounting plate and fittings for mast.	737589
Mounting plate	737588
Gasket kit for Antenna Tuning Unit / Aerial Coupler	737822

* (Please find specific order numbers in Operator's Manual)

